

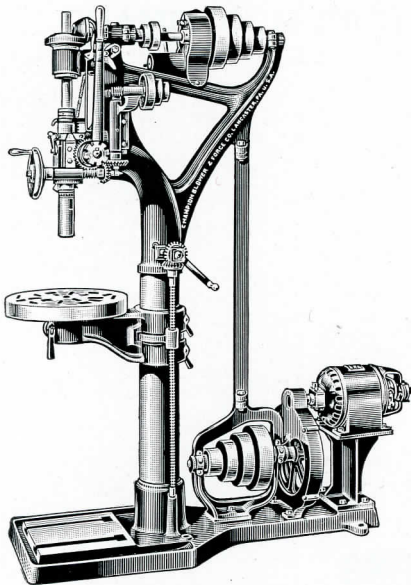

CHAMPION BACK-GEARED ELECTRICALLY DRIVEN UPRIGHT POWER DRILLS

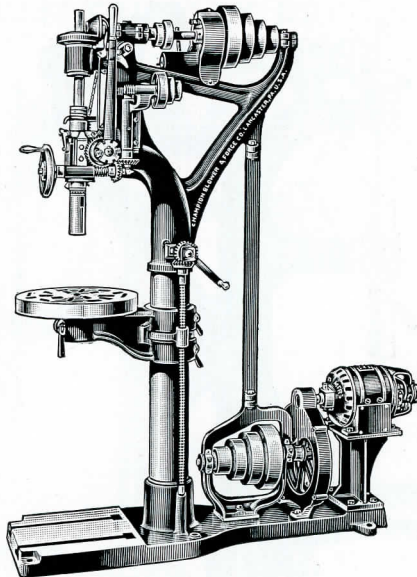

22"—Gear Driven



21"—Gear Driven

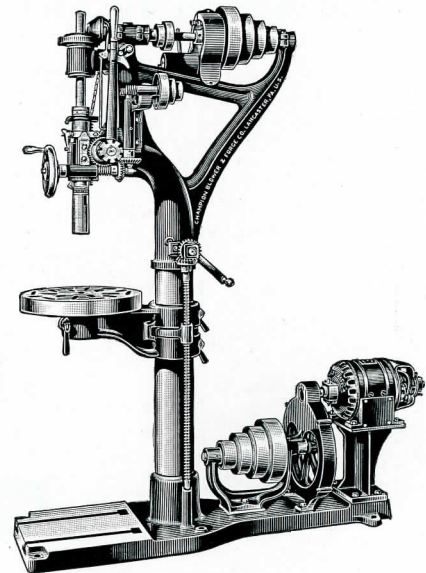

20"—Gear Driven

Champion 22-Inch, 21-Inch and 20-Inch Back-Geared Electrically Driven Upright Power Drills represent in every detail of construction the 22-Inch, 21-Inch and 20-Inch Drills as shown on pages 70, 71 and 72.

Supplied with a One Horsepower Motor, which can be placed either on a sub-base at the bottom of the drill, 13 inches from the floor, thereby keeping it free from dirt and dampness, geared to the drive shaft of the drill with steel cut pinion and gear; or can be furnished on a bracket at the top of the drill in such a position as to give a long belt between the motor and the drive pulley on the drill.

These Drills are supplied with safety starting switch attached at a convenient place in order that the operator can start or stop the drill without changing his position.

By referring to the description and dimensions of the 22-Inch, 21-Inch and 20-Inch Drills on the pages given above, it will be found that these drills are very practical and cover a wide range of work.

In ordering any of these drills state whether you desire the drill belt driven or gear driven; belt driven always furnished unless otherwise ordered; also advise whether your current is Direct or Alternating, and the Voltage—if alternating, the phase and cycles.

	Style	Weight	Code
22-Inch Back-Geared Electrically Driven Upright Power Drill, as shown on page 70, equipped with One Horsepower Motor	Belt Driven	1200 lbs.	Fiedmast
22-Inch Back-Geared Electrically Driven Upright Power Drill, as shown on page 70, equipped with One Horsepower Motor	Gear Driven	1200 lbs.	Finjan
21-Inch Back-Geared Electrically Driven Upright Power Drill, as shown on page 71, equipped with One Horsepower Motor	Belt Driven	1150 lbs.	Figlinos
21-Inch Back-Geared Electrically Driven Upright Power Drill, as shown on page 71, equipped with One Horsepower Motor	Gear Driven	1150 lbs.	Finiront
20-Inch Back-Geared Electrically Driven Upright Power Drill, as shown on page 72, equipped with One Horsepower Motor	Belt Driven	1050 lbs.	Fiedpost
20-Inch Back-Geared Electrically Driven Upright Power Drill, as shown on page 72, equipped with One Horsepower Motor	Gear Driven	1050 lbs.	Finiriez

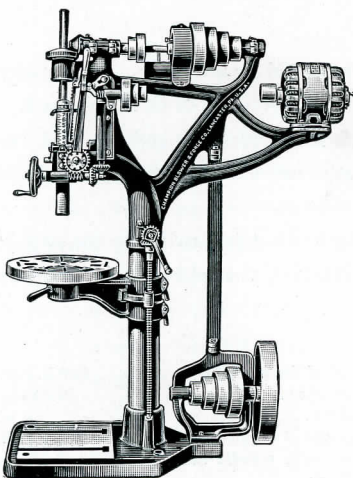

22"—Belt Driven

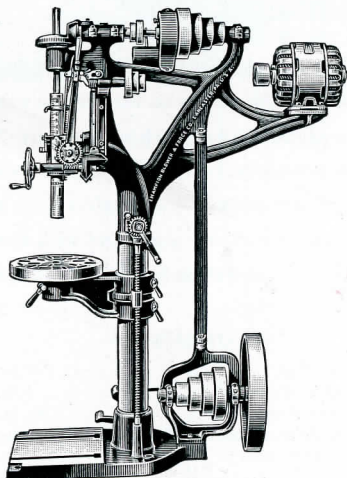

21"—Belt Driven

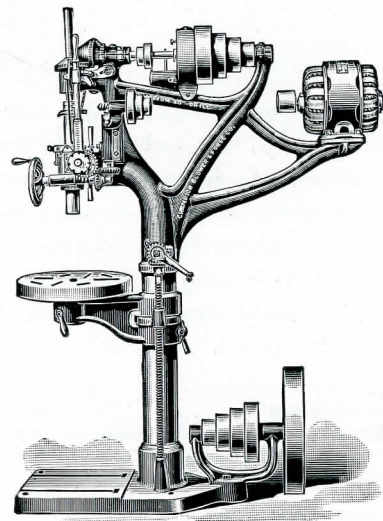

20"—Belt Driven