

NARDINI

**SPARE PARTS
AND
OPERATIONS MANUAL
FOR**

MS-1400S	(inch version)	MS-1600S
MS-1400E		MS-1600E
MS-175S	(metric version)	MS-205AS
MS-175E		MS-205AE

MANUFACTURED BY
INDÚSTRIAS NARDINI S.A.
Av. Mons. Bruno Nardini, 1735
13470 - Americana - SP - Brazil
Phone (0194) 61-4026
Tlx. 019 1551 INNA BR

UNITED STATES HEADQUARTERS
NARDINI INTERNATIONAL, INC.
9225 Eton Avenue
Chatsworth, California 91311
Phone (818) 700-1041
Tlx. 9104942107 NARDINT

INTRODUCTION

This manual describes the MASCOTE lathe models MS-1400S/E, MS-1600S/E, MS-175S/E and MS-205AS/AE.

It has been carefully prepared to assist you to take advantage of the qualities of these machines.

The first sections present instructions about foundation, leveling, lubrication; main-shaft adjustment, axial adjustment of the spindle, drive-belt adjustment and other details important to correct operation of the machine.

The second part presents blown-up views in perspective, parts list and information on ordering spare parts.

In the interest of continuing industrial and technological development, NARDINI reserves the right to change the design and specifications of its machines without previous notice.

NARDINI's expert technicians are always available to help you solve any problem in the operation of these machines.

The serial number of the lathe is stamped on the back part of the bed. For any claims please always refer to this number.

INDUSTRIAS NARDINI S.A.
Americana - SP - Brazil

INDEX

Specifications	5
Lifting and Cleanlines	6
Foundation	7
Levelling and Electrical Connections	8
Dimensions and Principal Assemblies	9
Lubrication	10
Oil change	11
Lathe Controls	12
Lathe Operations	13
Headstock Instructions	14
Threads and Feeds Gear Box Instructions	15
Threads and Feeds Gear Box Data Plate	16
Saddle Instructions	18
Apron (left - hand) Instructions	19
Apron (right - hand) Instructions	20
Tailstock Instructions	21
Motor Drive System Instructions	22
Change Gears and Safety Coupling Instructions	23
Threads Cutting Indicator Instructions (Leadscrew 4 TPI)	24
Threads Cutting Indicator Instructions (Leadscrew 6mm)	25
Spindle and Leadscrew Axle Adjustment Instructions	26
Brake System	27
Electrical Diagram	28
Part List Introduction	31
Headstock (MS-MI-401C)	32
Headstock (MS-MI-402C)	34
Headstock (MS-MI-403C)	36
Gear Box (MS-MI-404C)	38
Gear Box (MS-MI-405C)	40
Gear Box (MS-MI-406C)	42
Saddle (MS-MI-407C)	44
Apron (left - hand) (MS-MI-408C)	46
Apron (left - hand) (MS-MI-409C)	48
Tailstock (MS-MI-410C)	50
Bed (MS-MI-411C)	52
Change Gears (leadscrew 4 TPI) (MS-MI-412C)	54
Change Gears (leadscrew 6mm) (MS-MI-413C)	56
Motor Drive System (MS-MI-414C)	58
Steady Rest (MS-MI-415C)	59
Follow Rest (MS-MI-416C)	60
Tool Post (MS-MI-417C)	61
Drive Plate, Universal Chuck Flange, Back Plate (MS-MI-418C)	62
Taper Attachment (MS-MI-419C)	64
Coolant Pump (MS-MI-420C)	66
Threads Cutting Indicator (leadscrew 4 TPI) (MS-MI-421C)	67
Micrometer Stop (MS-MI-422C)	68
Chip Guard (MS-MI-423C)	70
Chuck Guard (MS-MI-424C)	71
Threads Cutting Indicator (leadscrew 6mm) (MS-MI-425C)	72
Apron (right - hand) (MS-MI-426C)	74
Apron (right - hand) (MS-MI-427C)	76

SPECIFICATIONS

	MS-1400 MS-175	MS-1600 MS-205	
CAPACITY			
Height of centers	6.7/8'' - 175	8.5/64'' - 205	. . . Inch/mm
Distance between centers	20'' - 500 32'' - 300	40'' - 1000	. . . Inch/mm
Swing over bed	13.25/32'' - 350	15.15/16'' - 405	. . . Inch/mm
Swing over wings of saddle	12.13/64'' - 310	14.9/16'' - 370	. . . Inch/mm
Swing in gap	20'' - 500	22.3/64'' - 560	. . . Inch/mm
Gap length in front of faceplate	5.45/64'' - 145		. . . Inch/mm
Cross slide travel	8'' - 205	9.1/4'' - 235	. . . Inch/mm
Top slide travel	4'' 100		. . . Inch/mm
Tool section	5/8''x5/8'' - 16x16		. . . Inch/mm
 BED			
Widht	8.21/32'' - 220		. . . Inch/mm
Height	11.13/16'' - 300		. . . Inch/mm
 HEADSTOCK			
Spindle bore	1.13/16'' - 46 *		. . . Inch/mm
Spindle nose	ASA L-O**	
Spindle internal taper	1:20	
Taper in reduction sleeve	3	 MT
 Spindle speeds:			
MS-175S, 205AS, 1400S and 1600S	9	
MS-175E, 205AE, 1400E and 1600E	18	
Speeds range:			
MS-175S, 205S, 1400S and 1600S	50 to 2000	 rpm
MS-175E, 205E, 1400E and 1600E	25 to 2000	 rpm
 TAILSTOCK			
Quill diameter	2'' - 50		. . . Inch/mm
Quill internal taper	3	 MT
Quill travel	5.33/64'' - 140		. . . Inch/mm
Lateral adjustment	3/8'' - 10		. . . Inch/mm
 GEAR BOX - Pitch of Leadscrew - 6mm			
Threads number	192	
Metric threads (64)	0,375 to 7,0	 mm
Inch threads (32)	3 to 56	 Inch
Module threads (64)	0,1875 to 3,5	 MOD
Diametral pitch threads (32)	12 to 208	 DP
FEEDS RANGE			
Number of feeds	256	
Longitudinal feeds (128)	0,042 to 0,929	 mm Rev
Cross feeds (128)	0,015 to 0,338	 mm Rev
 GEAR BOX - Pitch of Leadscrew 4 T.P.I.			
Threads number	135	
Metric threads (45)	0,4 to 7,0	 mm
Inch threads (33)	3 to 5,6	 Inch
Module threads (25)	0,25 to 3,75	 MOD
Diametral pitch threads (32)	12 to 208	 DP
FEEDS RANGE			
Number of feeds	256	
Longitudinal feeds (128)	0,0015'' to 0,0427'' - 0,038 to 1,085		Inch/mm Rev
Cross feeds (128)	0,00075'' to 0,02135'' - 0,019 to 0,5425		Inch/mm Rev
 MOTORS			
Main motor:			
MS-175S, 205S, 1400S and 1600S	6 (60Hz) or 5,5 (50Hz) (one speed motor)		. . . HP
MS-175E, 205E, 1400E and 1600E	6,3/4 (two speed motor)	 HP
Coolant pump	0,12	 HP
Optional			
** Cam Lock D1 - 5	- * 1.21/32'' (42mm)		
** Cam Lock DIN 55022-5	- * 1.13/16'' (46mm)		
Under Request			
** Cam Lock D1-6 or DIN 55022-6	- * 2.1/32'' (52mm)		

LIFTING

To raise the lathe, move the transversal carriage and tailstock to the right extremity of the bed and fix them, making sure that they will not slide and cause damage to others parts.

Put an square steel bar of aproximated 2" (50mm) under the bed. place the cables through the first vertical discharge for chips and tie on the square steel bar.

For safety precautions, prop the cables with wooden blocks.

When the lifting process begins the cables are taut, check if the square steel bar is uphelded and leveled properly.

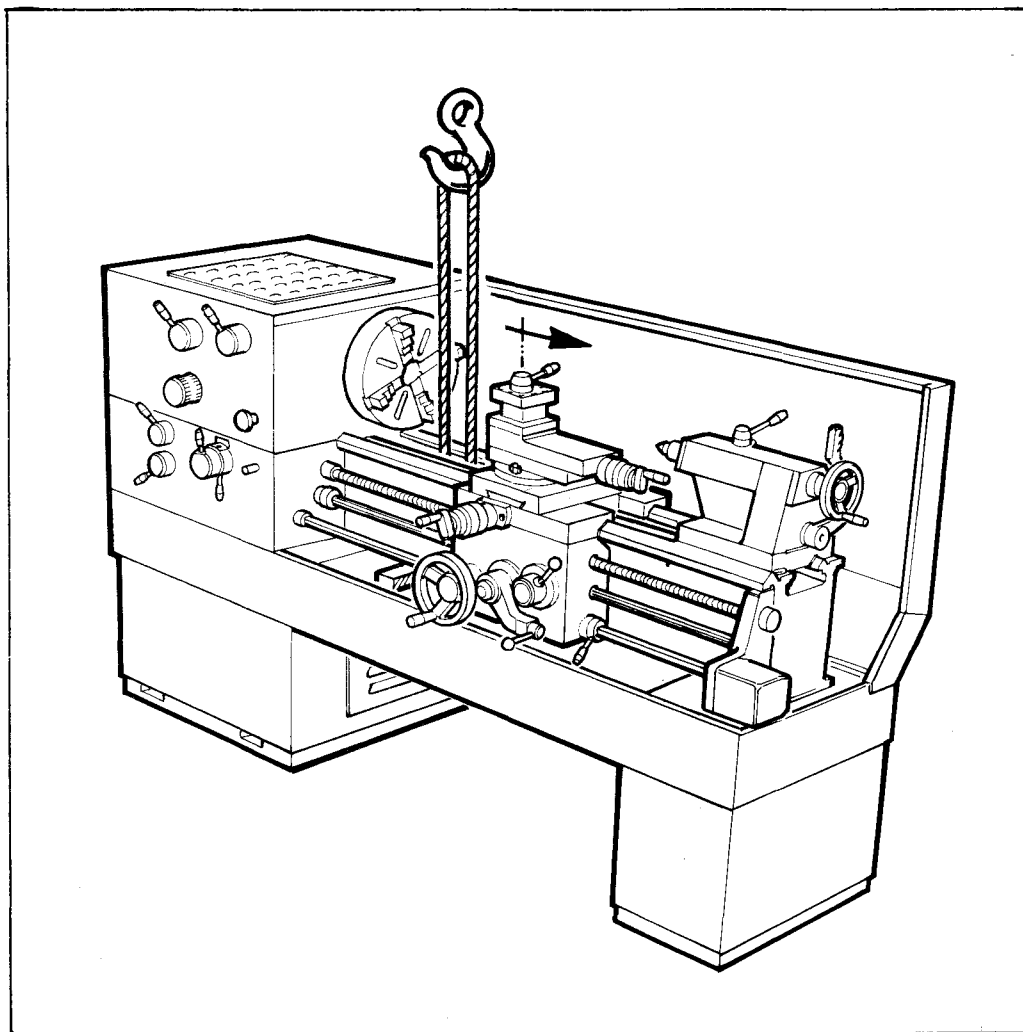

CLEANLINESS

All NARDINI lathes leave the factory protected by grease and preventatives which must be removed. Use a soft cloth moistened with kerosene.

Do not use thinner, gasoline or other kinds of removers.

Give special attention to cleaning the guides of the bed and then lubricate them.

FOUNDATION

The precision of the lathe depends on how well it is installed. The durability of the machine is only guaranteed if the lathe has been firmly and precisely installed.

The foundation area must consist of good concret and have minimum depth of 12'' (300mm) to support the lathe's weight at the columns areas.

NOTE: Anchor screws and plates are not included with the machine.

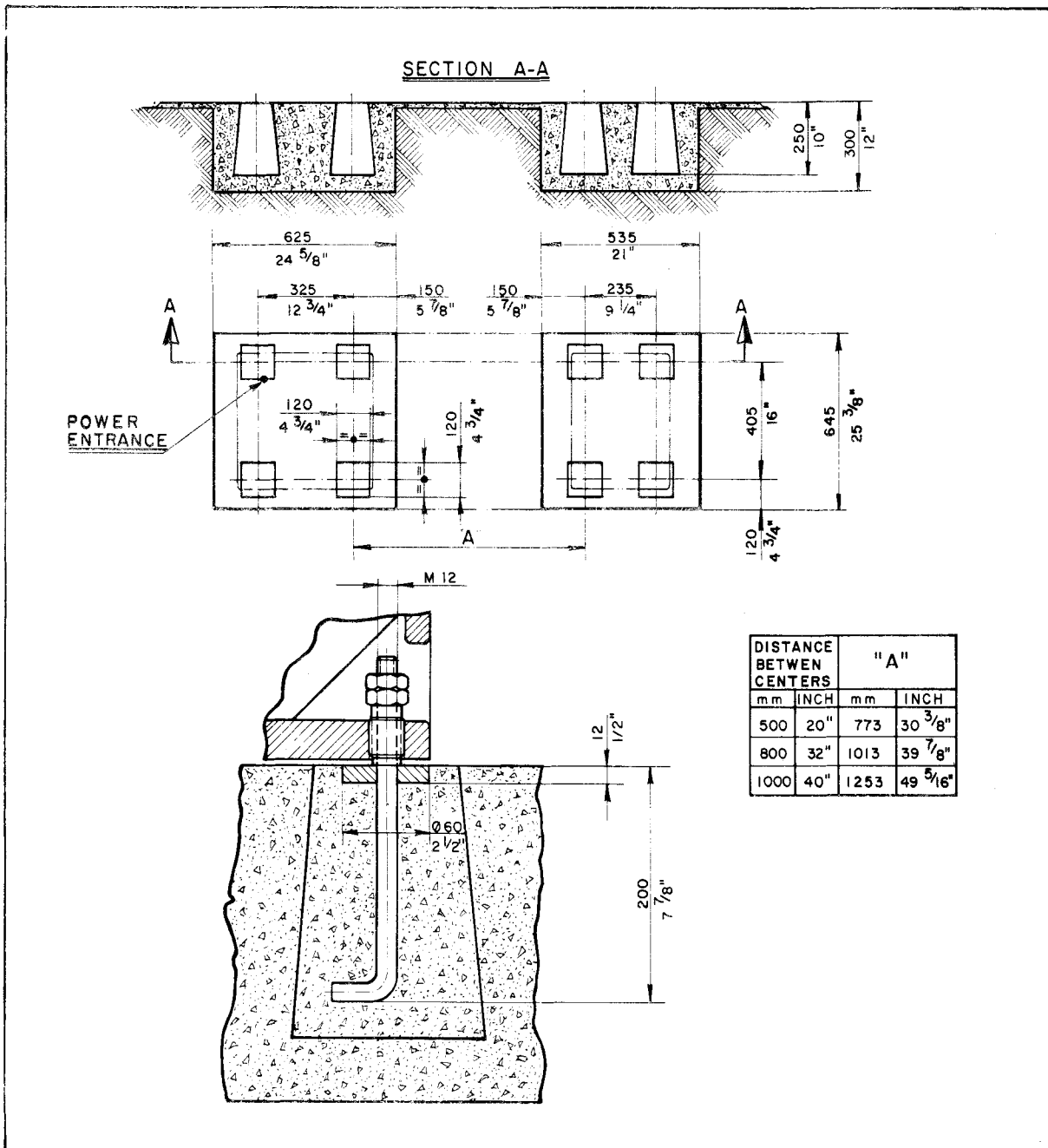

LEVELING

The precision and durability of the lathe depends on its being perfectly level. Final inspection must be done only when the machine has been correctly leveled. When the machine is on its foundation, level readings must be done with the level in positions A, B, C and D (see figure). Use a precise level of 0.0008"x40" (0,02/1000mm)

The transversal reading must be done using a precision level (1) and two parallel wedges (2).

Care must be taken that the machine is not moved until the screws are fixed in the concrete (minimum 48 hours). After his period of time, use the precision level again to obtain a perfect levelness.

Note - Leveling of the machine should be checked again after the first week of the operation to ensure its permanency. Repeat this operation each six months.

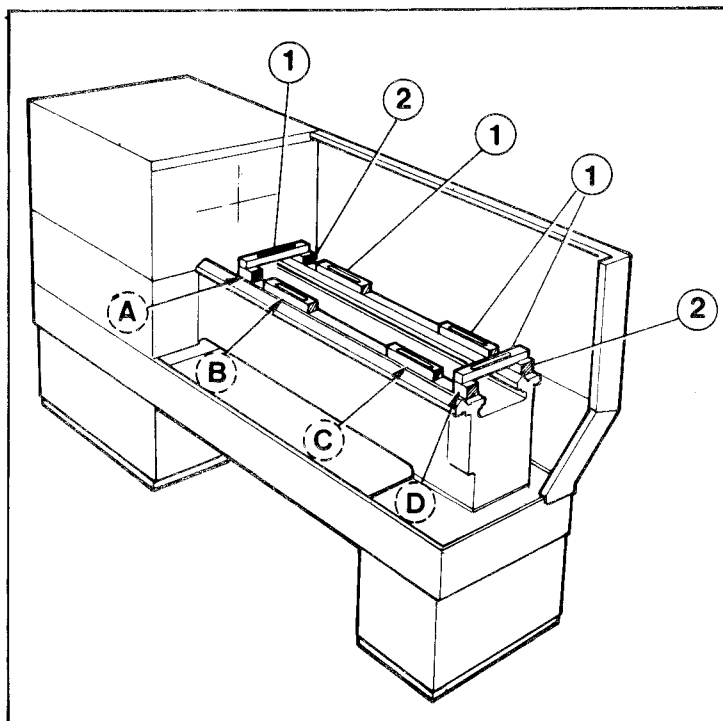

ELECTRICAL CONNECTIONS

All electrical connections are by L1, L2, L3 and GRD terminals found in the electrical cabinet, which is equipped with circuit breakers and contactors.

Before connecting the lathe to power source, ensure that the source does not vary more than + 10 or - 5%. Variations outside this range may be harmful.

The power lines must be well dimensioned, by preference 4x6mm² (L1, L2, L3 and GRD).

We recommend the grounding for your protection (see electrical diagrams).

The following is recommended for preventive maintenance of electrical system –

Every three months - Tighten all contact screw.

Every six months - Clean the motor and its electrical connections.
Clean all electrical equipment, including microswitches, cabinets and pumps.

Annually - If necessary, change the contacts.

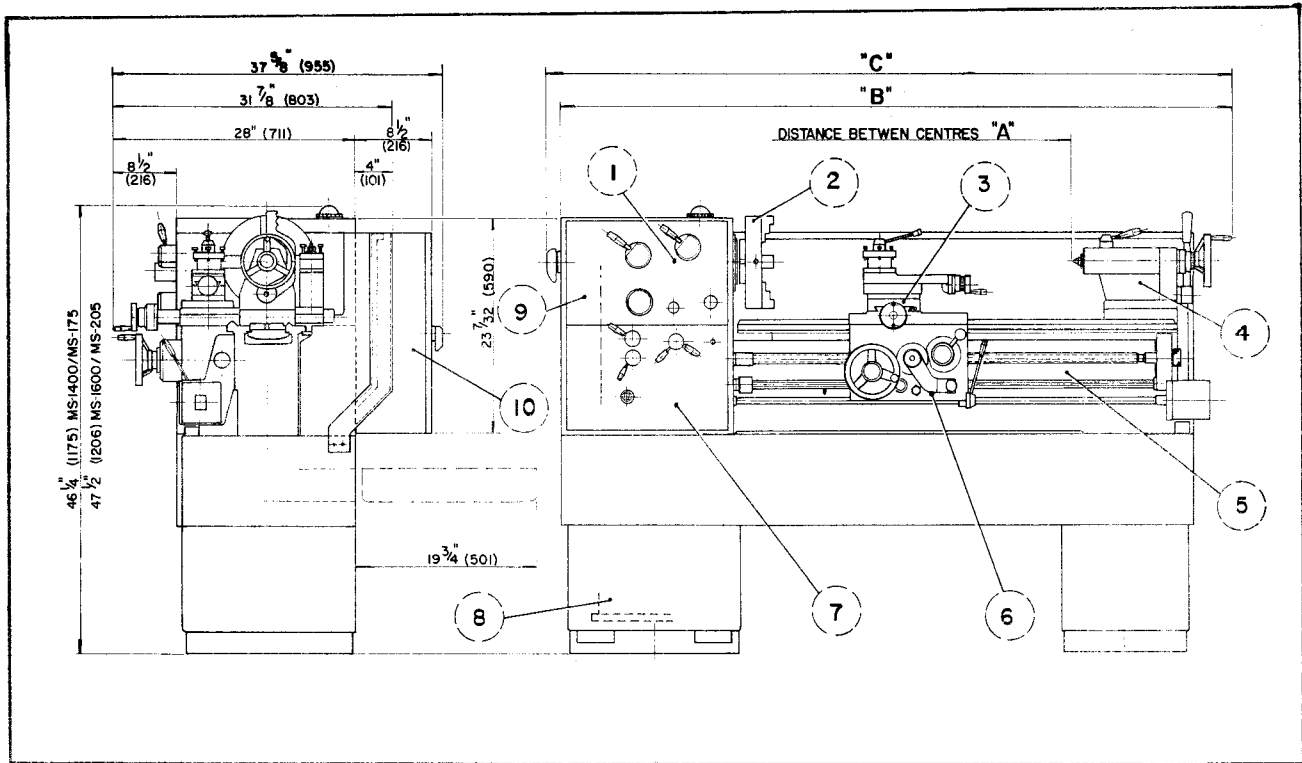

PRINCIPAL ASSEMBLIES

1. Headstock
2. Four independent jaw chuck
3. Saddle
4. Tailstock
5. Bed
6. Apron
7. Gear box
8. Drive unit
9. Change gears
10. Electric panel

DIMENSIONS

A	B	C
20" 500mm	64.1/2" 1638mm	66.1/8" 1680mm
32" 800mm	73.1/2" 1867mm	75.1/8" 1908mm
40" 1000mm	83.1/8" 2111mm	84.3/4" 2153mm

LUBRICATION

The machine must be lubricated with strict regularity. Before using the lathe, the operator should familiarize himself with all lubrication points (see figure below), verify that they are lubricated correctly and thereafter take responsibility for regular lubrication of the machine.

TABLE OF EQUIVALENT LUBRICANTS

SUPPLIERS	RECOMMENDED OILS	RECOMMENDED GREASES
CASTROL	Hyspin AWS-68	Castrol LM Grease
SHELL	Tellus 68	Alvania EP-2
TEXACO	Rando HD-68	Marfax All Purpose or Multifak EP-2
EXXON	Teresso/Turbine Oil 68	Beacon 2
MOBIL	DTE-26	Mobil Grease MP
E.F. HOUGHTON	Hydro Drive HP-68	LA-2

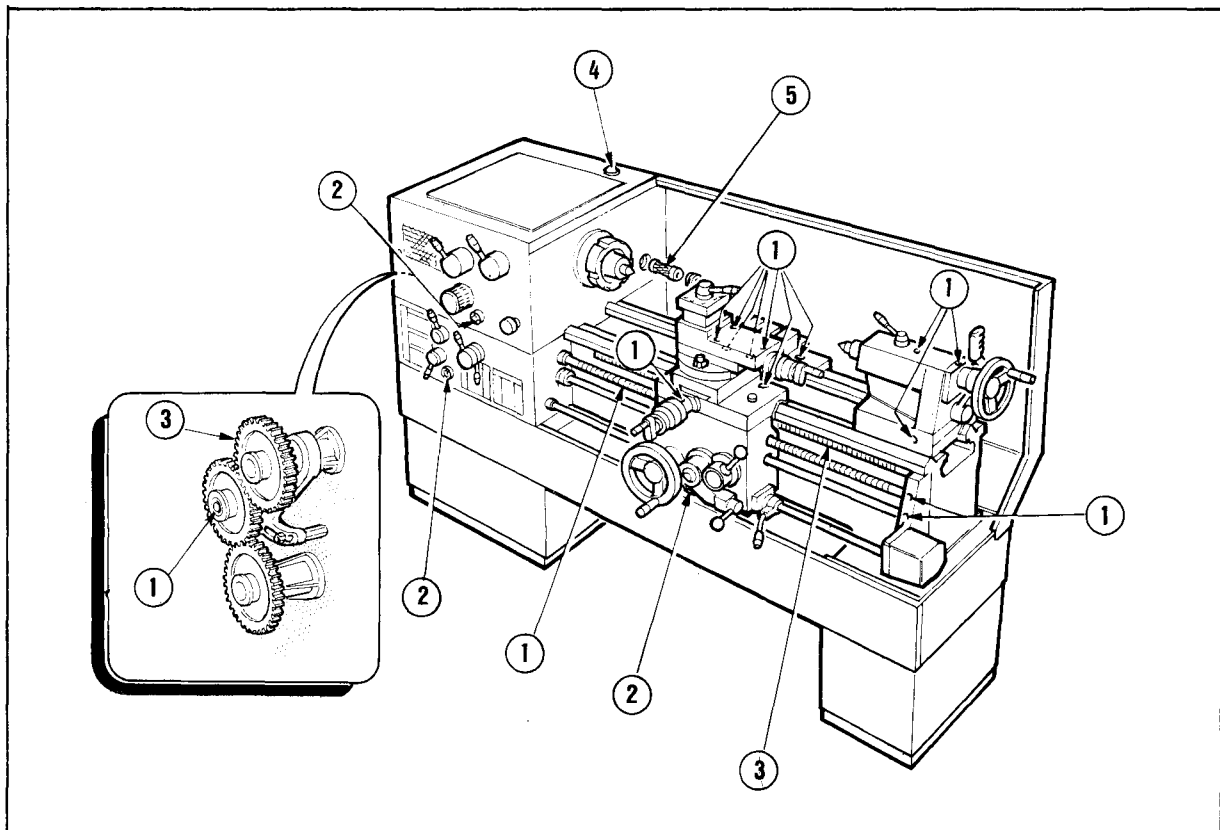

GENERAL LUBRICATION

1. Oil lubrication points (daily)
2. Oil level indicator.
3. Grease lubrication points (weekly)
4. Headstock oil sight.
5. Headstock oil filter (clean it annually in the oil changing)

LUBRICATION

ASSEMBLY	FREQUENCY OF OIL CHANGE	QUANTITY
HEADSTOCK	ANNUALLY	3,5 LITRES
GEAR BOX		2,5 LITRES
APRON		1,5 LITRES

TO CHANGE OIL

HEADSTOCK

Drain the oil through plug (2).
Refill with fresh oil through the oil sight (1).

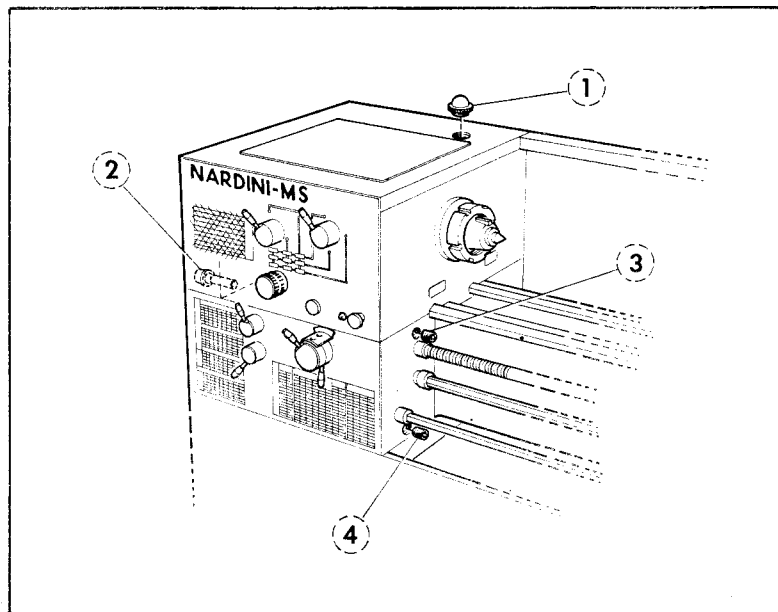

GEAR BOX

Drain the oil through plug (4).
Refill with fresh oil through the plug (3).

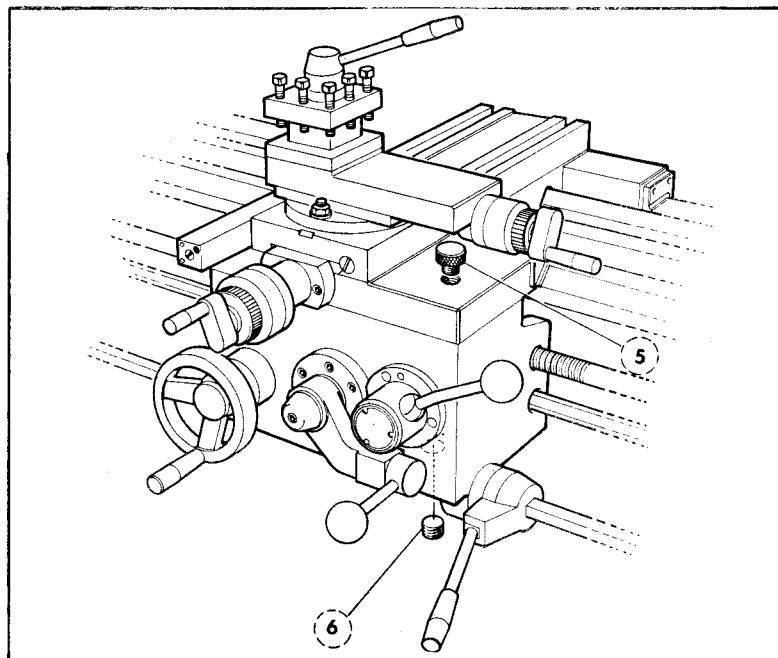

APRON

Drain the oil through plug (6).
Refill with fresh oil through the plug (5).

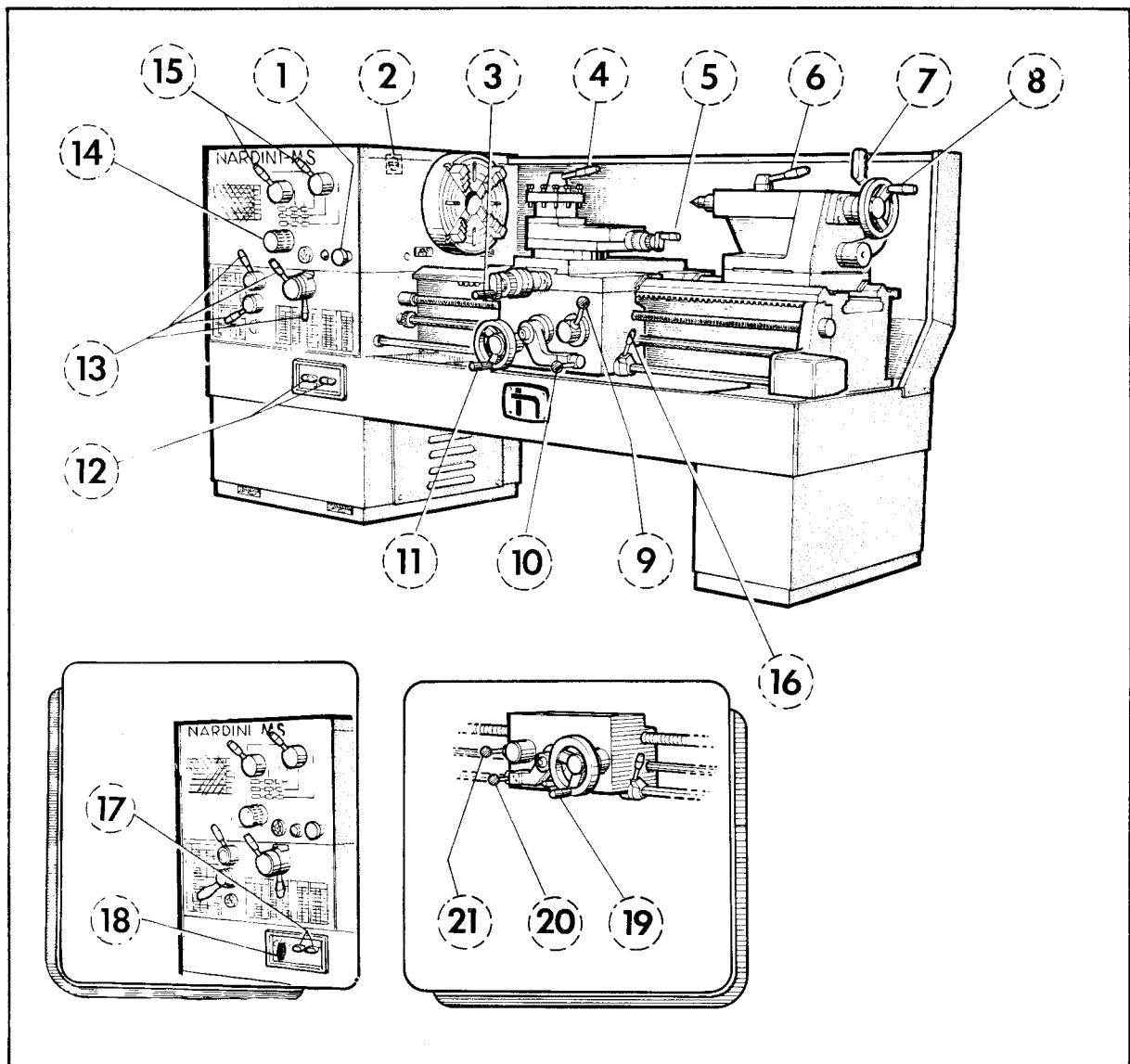

LATHE CONTROLS

- | | |
|---|--|
| <ul style="list-style-type: none"> 1. Circuit control ON and emergency stop. 2. General switch. 3. Cross slide handle. 4. Toolpost handle. 5. Top slide handle. 6. Tailstock barrel lever. 7. Tailstock clamp lever. 8. Tailstock handwheel. 9. Lever for engaging the leadscrew nut, the longitudinal and transversal feeds. 10. Engage and disengage of automatic feeds lever. 11. Apron handwheel. 12. Coolant pump ON/OFF button. 13. Threads and feeds selectors. 14. Saddle longitudinal motion handle. | <ul style="list-style-type: none"> 15. Spindle speeds selectors. 16. Spindle rotation forward, reverse and stop. <p style="text-align: center;">For models MS-1400E, MS-175E
MS-1600E and MS-205AE</p> <ul style="list-style-type: none"> 17. Coolant pump ON/OFF button. 18. Low and high main motor rotation. <p style="text-align: center;">For righthand apron models</p> <ul style="list-style-type: none"> 19. Apron handwheel. 20. Engage and disengage of automatic feeds levers. 21. Lever for engaging the leadscrew nut, the longitudinal and transversal feeds. |
|---|--|

LATHE OPERATION

CAUTIONS -

- To safeguard against damage or injury, it is recommended that the operator read carefully all instructions in this manual before beginning operation of the lathe.

- Check the oil level of the headstock and lubrication of the threads, feeds gear box and all other lubrication points. The lathe leaves the factory correctly lubricated at all points, but a general inspection before operation is important.

- Before cleaning the lathe, verify that the spindle lever is in the center position.

- Until the operator has become completely familiarized with all the lathe's controls, he should operate it only with the motor at low speed.

IMPORTANT -

Do not change speeds, threads or feeds selectors with the spindle in motion. This can wear or break the gear teeth.

**HEADSTOCK FOR MODELS:
MS-1400S, MS-1600S, MS-175S and MS-205AS**

Selection of speeds is through the handle wheels (1) and (2). These controls allow 9 different speeds. When the circuit control and emergency stop buttons (4) are pulled out, all electric commands of the lathe are ON. Pushing them in bring the reverse - all commands are OFF. The handle wheel (3) controls the rotation of the leadscrew, bringing it to reverse or to full stop.

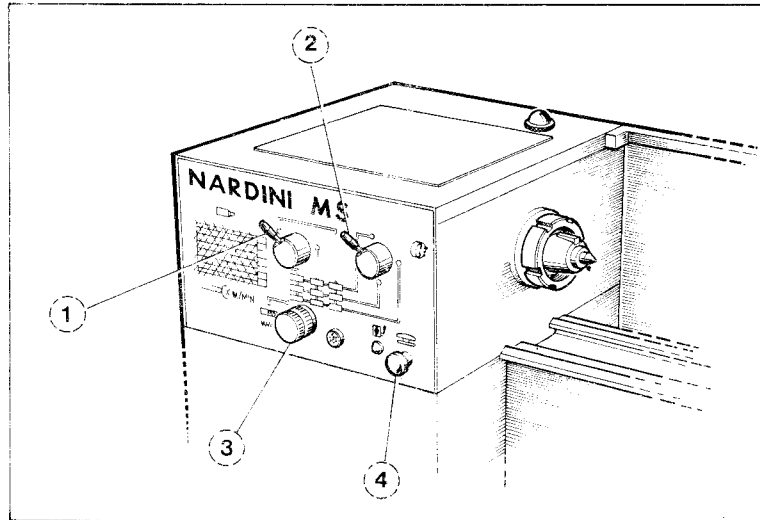

**HEADSTOCK FOR MODELS:
MS-1400E, MS-1600E, MS-175E and MS-205AE**

Selection of speeds is through the handle wheels (1) and (2). These controls allow 9 different speeds. Nine additional speeds may be obtained by changing motor speed from low to high rotation, or vice-versa, through key (4), giving a total of 18 speeds. When circuit control and emergency stop buttons (5) are pulled out, all electric commands of the lathe are ON. Pushing them in brings the reverse - all commands are OFF. The handle (3) controls the rotation of the leadscrew, bringing it to reverse or to full stop.

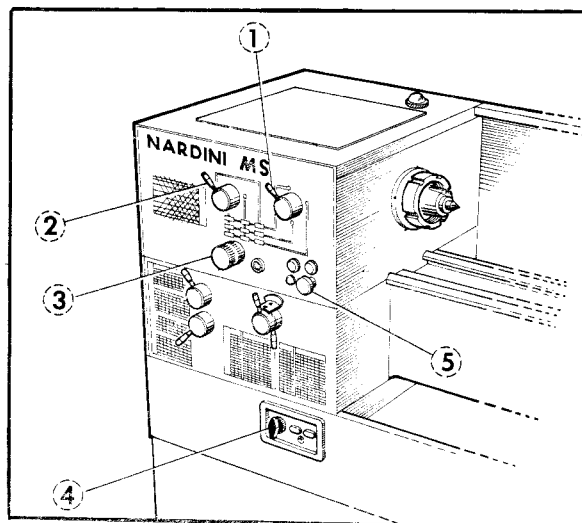

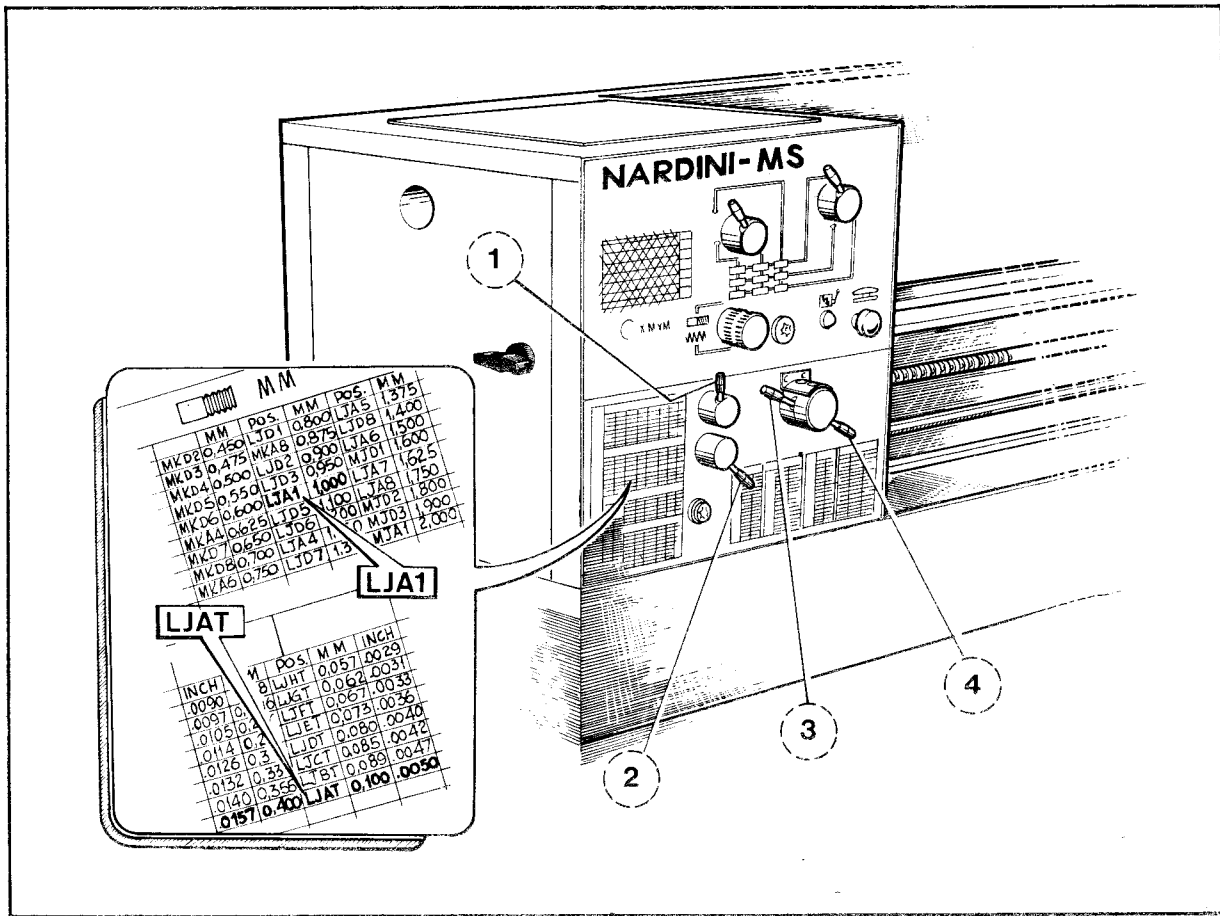

THREADS AND FEEDS GEAR BOX

Selection of threads is through levers (1), (2), (3) and (4).

The lubrication is made by an internal pump placed in the box, with reservoirs and channels distributed through the whole set, guaranteeing that every part is well lubricated.

To set a specific pitch of thread or feed, find it on the data plate the value of this pitch. Then, on the same line, find the letters and numbers that indicate the position of levers (1), (2), (3) and (4)

Example : Tooling of a metric thread pitch of 1mm.

- Locate the pitch on the data plate.
- Set the levers according to the letters and numbers corresponding to pitch 1,00 (LJA1).
- The assembly is now prepared to make threads of 1mm pitch.

To obtain a tooling with transversal and longitudinal advances, proceed in the same way.

GEAR BOX DATA PLATE (Leadscrew pitch: 4TPI)

M.M.

POS.	mm	POS.	mm	POS.	mm	POS.	mm	POS.	mm
LKD1	0.400	MKD2	0.900	LJD1	1.600	LJA5	2.750	MJD5	4.400
LKD2	0.450	MKD3	0.950	MKA8	1.750	LJD8	2.800	MJD6	4.800
LKB2	0.500	MKD4	1.000	LJD2	1.800	LJA6	3.000	MJA4	5.000
LKD5	0.550	MKD5	1.100	LJD3	1.900	MJD1	3.200	MJD7	5.200
LKD6	0.600	MKD6	1.200	LJA1	2.000	LJA7	3.250	MJA5	5.500
LKD7	0.650	MKA4	1.250	LJD5	2.200	LJA8	3.500	MJD8	5.600
LKD8	0.700	MKD7	1.300	LJD6	2.400	MJD2	3.600	MJA6	6.000
LKA6	0.750	MKD8	1.400	LJA4	2.500	MJD3	3.800	MJA7	6.500
MKD1	0.800	MKA6	1.500	LJD7	2.600	MJA1	4.000	MJA8	7.000

x INCH / M.M.

INCH	POS.	mm	INCH	POS.	mm	INCH	POS.	mm
.0015	LKHT	0.038	.0039	MKET	0.099	.0096	LJBT	0.244
.0016	LKGT	0.040	.0043	MKDT	0.109	.0108	LJAT	0.274
.0018	LKFT	0.046	.0045	MKCT	0.114	.0124	MJHT	0.315
.0019	LKET	0.048	.0048	MKBT	0.122	.0134	MJGT	0.340
.0021	LKDT	0.053	.0054	MKAT	0.137	.0145	MJFT	0.368
.0022	LKCT	0.056	.0062	LJHT	0.157	.0158	MJET	0.400
.0024	LKBT	0.060	.0067	LJGT	0.170	.0174	MJDT	0.442
.0027	LKAT	0.068	.0072	LJFT	0.183	.0183	MJCT	0.466
.0031	MKHT	0.079	.0079	LJET	0.200	.0193	MJBT	0.490
.0033	MKGT	0.084	.0087	LJDT	0.221	.0217	MJAT	0.552
.0036	MKFT	0.090	.0091	LJCT	0.231			

MOD.

POS.	MOD.	POS.	MOD.	POS.	MOD.	POS.	MOD.	POS.	MOD.
LKD1	0.250	MKD8	0.875	LJD6	1.500	MJD2	2.250	MJA4	3.125
LKD6	0.375	LJD1	1.000	LJD7	1.625	MJD3	2.375	MJD7	3.250
MKD1	0.500	LJD2	1.125	LJD8	1.750	MJG7	2.500	MJB6	3.333
MKA1	0.625	LJB2	1.250	LJA6	1.875	MJD5	2.750	MJD8	3.500
MKD6	0.750	LJD5	1.375	MJD1	2.000	MJD6	3.000	MJA6	3.750

x INCH / M.M.

INCH	POS.	mm	INCH	POS.	mm	INCH	POS.	mm
.0030	LKHT	0.075	.0078	MKET	0.198	.0190	LJBT	0.483
.0033	LKGT	0.084	.0085	MKDT	0.216	.0214	LJAT	0.544
.0036	LKFT	0.091	.0090	MKCT	0.228	.0244	MJHT	0.620
.0039	LKET	0.099	.0095	MKBT	0.241	.0263	MJGT	0.668
.0043	LKDT	0.109	.0107	MKAT	0.272	.0285	MJFT	0.724
.0045	LKCT	0.114	.0122	LJHT	0.310	.0311	MJET	0.790
.0047	LKBT	0.119	.0131	LJGT	0.332	.0342	MJDT	0.868
.0053	LKAT	0.135	.0142	LJFT	0.361	.0360	MJCT	0.914
.0061	MKHT	0.155	.0155	LJET	0.394	.0380	MJBT	0.965
.0066	MKGT	0.168	.0171	LJDT	0.434	.0427	MJAT	1.085
.0071	MKFT	0.180	.0180	LJCT	0.457			

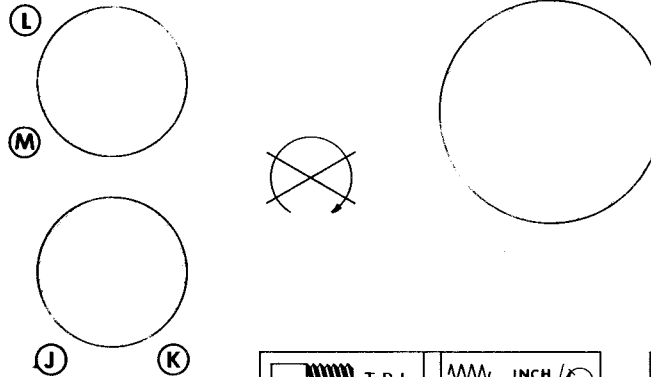

T.P.I.

POS.	T.P.I.	INCH	POS.	mm
MJB6	3	.0025	LKHT	0.063
MJA1	4	.0026	LKGT	0.066
MJB1	4.1/2	.0029	LKFT	0.074
MJC1	4.3/4	.0031	LKET	0.079
MJD1	5	.0034	LKDT	0.086
MJE1	5.1/2	.0036	LKCT	0.091
MJF1	6	.0038	LKBT	0.096
MJG1	6.1/2	.0043	LKAT	0.109
MJH1	7	.0049	MKHT	0.124
LJA1	8	.0053	MKGT	0.135
LJB1	9	.0058	MKFT	0.147
LJC1	9.1/2	.0063	MKET	0.160
LJD1	10	.0069	MKDT	0.175
LJE1	11	.0073	MKCT	0.185
LJF1	12	.0077	MKBT	0.195
LJG1	13	.0086	MKAT	0.218
LJH1	14	.0099	LJHT	0.251
MKA1	16	.0106	LJGT	0.269
MKB1	18	.0115	LJFT	0.292
MKC1	19	.0126	LJET	0.320
MKD1	20	.0138	LJDT	0.350
MKE1	22	.0145	LJCT	0.368
MKF1	24	.0154	LJBT	0.391
MKG1	26	.0173	LJAT	0.439
MKH1	28	.0197	MJHT	0.500
LKA1	32	.0213	MJGT	0.540
LKB1	36	.0230	MJFT	0.584
LKC1	38	.0251	MJET	0.638
LKD1	40	.0276	MJDT	0.701
LKE1	44	.0291	MJCT	0.739
LKF1	48	.0307	MJBT	0.780
LKG1	52	.0346	MJAT	0.879
LKH1	56			

D. PITCH

POS.	D.P.	INCH	POS.	mm
MJB6	12	.0019	LKHT	0.048
MJF6	16	.0021	LKGT	0.053
MJB1	18	.0023	LKFT	0.058
MJC1	19	.0025	LKET	0.063
MJD1	20	.0027	LKDT	0.068
MJE1	22	.0028	LKCT	0.071
MJF1	24	.0030	LKBT	0.076
MJG1	26	.0034	LKAT	0.086
MJH1	28	.0039	MKHT	0.099
LJG7	32	.0042	MKGT	0.107
LJB1	36	.0045	MKFT	0.114
LJC1	38	.0049	MKET	0.124
LJD1	40	.0054	MKDT	0.137
LJE1	44	.0057	MKCT	0.145
LJF1	48	.0060	MKBT	0.152
LJG1	52	.0068	MKAT	0.173
LJH1	56	.0077	LJHT	0.195
MKA1	64	.0083	LJGT	0.210
MKB1	72	.0090	LJFT	0.228
MKC1	76	.0099	LJET	0.251
MKD1	80	.0109	LJDT	0.276
MKE1	88	.0114	LJCT	0.289
MKF1	96	.0121	LJBT	0.307
MKG1	104	.0136	LJAT	0.345
MKH1	112	.0155	MJHT	0.394
LKA1	128	.0167	MJGT	0.424
LKB1	144	.0181	MJFT	0.460
LKC1	152	.0197	MJET	0.500
LKD1	160	.0217	MJDT	0.551
LKE1	176	.0229	MJCT	0.582
LKF1	192	.0241	MJBT	0.612
LKG1	208	.0271	MJAT	0.688

1:1=LJD4

GEAR BOX DATA PLATE (Leadscrew pitch: 6mm)

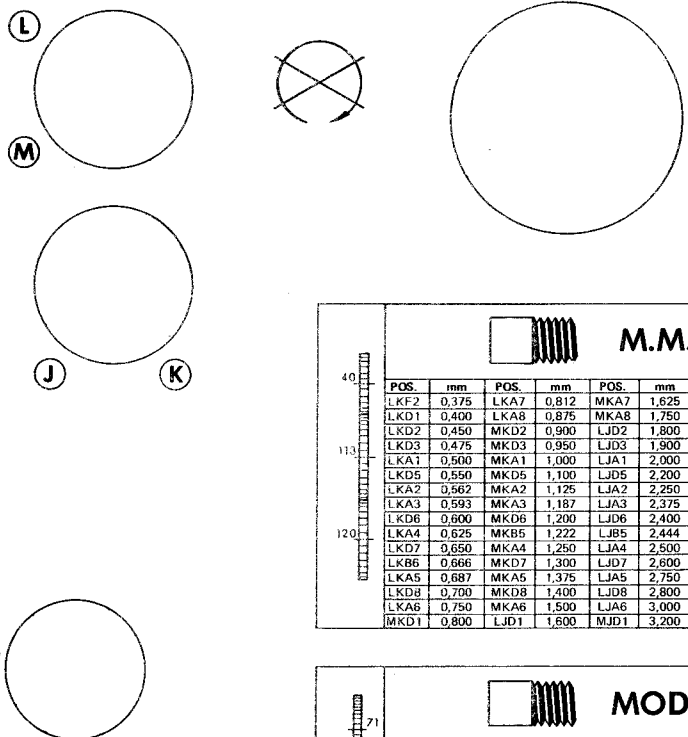

T.P.I.		mm / ϕ							
POS.	T.P.I.	POS.	T.P.I.	mm	POS.	mm	mm	POS.	mm
MJB6	3	MKA1	16	0.066	LKHT	0.024	0.266	LJHT	0.096
MJA1	4	MKB1	18	0.071	LKGT	0.026	0.286	LJGT	0.104
MJB1	4.1/2	MKC1	19	0.077	LKFT	0.028	0.310	LJFT	0.113
MJD1	5	MKD1	20	0.084	LKET	0.031	0.338	LJET	0.122
MJE1	5.1/2	MKE1	22	0.093	LKDT	0.034	0.372	LJDT	0.135
MJF1	6	MKF1	24	0.098	LKCT	0.036	0.391	LJCT	0.142
MJG1	6.1/2	MKG1	26	0.103	LKBT	0.038	0.413	LJBT	0.150
MJH1	7	MKH1	28	0.116	LKAT	0.042	0.465	LJAT	0.169
LJA1	8	LKA1	32	0.133	MKHT	0.048	0.531	MJHT	0.193
LJB1	9	LKB1	36	0.143	MKGT	0.052	0.572	MJGT	0.208
LJC1	9.1/2	LKC1	38	0.155	MKFT	0.056	0.620	MJFT	0.225
LJD1	10	LKD1	40	0.169	MKET	0.061	0.676	MJET	0.246
LJE1	11	LKE1	44	0.186	MKDT	0.068	0.743	MJDT	0.270
LJF1	12	LKF1	48	0.196	MKCT	0.071	0.783	MJCT	0.284
LJG1	13	LKG1	52	0.207	MKBT	0.075	0.826	MJBT	0.300
LJHT	14	LKHT	56	0.232	MKAT	0.084	0.929	MJAT	0.338

M.M.		mm / ϕ											
POS.	mm	POS.	mm	POS.	mm	POS.	mm	mm	POS.	mm	mm	POS.	mm
LKF2	0.375	LKA7	0.812	MKA7	1.625	LJA7	3.250	0.042	LKHT	0.015	0.167	LJHT	0.061
LKD1	0.400	LKA8	0.875	MKA8	1.750	LJA8	3.500	0.045	LKGT	0.016	0.180	LJGT	0.065
LKD2	0.450	MKD2	0.900	LJD2	1.800	MJD2	3.600	0.049	LKFT	0.018	0.195	LJFT	0.071
LKD3	0.475	MKD3	0.950	LJD3	1.900	MJD3	3.800	0.053	LKET	0.019	0.213	LJET	0.077
LKA1	0.500	MKA1	1.000	LJA1	2.000	MJA1	4.000	0.059	LKDT	0.021	0.224	LJDT	0.085
LKD5	0.550	MKD5	1.100	LJD5	2.200	MJD5	4.400	0.062	LKCT	0.022	0.246	LJCT	0.090
LKA2	0.562	MKA2	1.125	LJA2	2.250	MJA2	4.500	0.065	LKBT	0.024	0.260	LJBT	0.095
LKA3	0.593	MKA3	1.187	LJA3	2.375	MJA3	4.750	0.073	LKAT	0.027	0.293	LJAT	0.106
LKD6	0.600	MKD6	1.200	LJD6	2.400	MJD6	4.800	0.084	MKHT	0.030	0.335	MJHT	0.122
LKA4	0.625	MKA4	1.250	LJA4	2.500	MJA4	5.000	0.090	MKGT	0.033	0.360	MJGT	0.131
LKD7	0.650	MKD7	1.300	LJD7	2.600	MJD7	5.200	0.098	MKFT	0.035	0.390	MJFT	0.142
LKB6	0.666	MKB6	1.333	LJB6	2.666	MJB6	5.333	0.106	MKET	0.039	0.426	MJET	0.155
LKA5	0.687	MKA5	1.375	LJA5	2.750	MJA5	5.500	0.117	MKDT	0.043	0.468	MJDT	0.170
LKD8	0.700	MKD8	1.400	LJD8	2.800	MJD8	5.600	0.123	MKCT	0.045	0.493	MJCT	0.179
LKA6	0.750	MKA6	1.500	LJA6	3.000	MJA6	6.000	0.130	MKBT	0.047	0.520	MJBT	0.189
MKD1	0.800	LJD1	1.600	MJD1	3.200	MJA8	7.000	0.148	MKAT	0.053	0.585	MJAT	0.213

D.P.		mm / ϕ							
POS.	D.P.	POS.	D.P.	mm	POS.	mm	mm	POS.	mm
MJB6	12	LJH1	56	0.052	LKHT	0.019	0.209	LJHT	0.076
MJA1	16	MKA1	64	0.056	LKGT	0.020	0.225	LJGT	0.082
MJB1	18	MKB1	72	0.061	LKFT	0.022	0.243	LJFT	0.088
MJC1	19	MKC1	76	0.066	LKET	0.024	0.265	LJET	0.096
MJD1	20	MKD1	80	0.073	LKDT	0.027	0.292	LJDT	0.106
MJE1	22	MKE1	88	0.077	LKCT	0.028	0.307	LJCT	0.112
MJF1	24	MKF1	96	0.081	LKBT	0.029	0.324	LJBT	0.118
MJG1	26	MKG1	104	0.091	LKAT	0.033	0.365	LJAT	0.133
MJH1	28	MKH1	112	0.104	MKHT	0.038	0.417	MJHT	0.152
LJA1	32	LKA1	128	0.112	MKGT	0.041	0.449	MJGT	0.163
LJB1	36	LKB1	144	0.122	MKFT	0.044	0.487	MJFT	0.177
LJC1	38	LKC1	152	0.133	MKET	0.048	0.531	MJET	0.193
LJD1	40	LKD1	160	0.146	MKDT	0.053	0.584	MJDT	0.212
LJE1	44	LKE1	176	0.154	MKCT	0.056	0.615	MJCT	0.223
LJF1	48	LKF1	192	0.162	MKBT	0.059	0.649	MJBT	0.236
LJG1	52	LKG1	208	0.182	MKAT	0.066	0.730	MJAT	0.265

MOD.		mm / ϕ											
POS.	MOD.	POS.	MOD.	POS.	MOD.	POS.	MOD.	mm	POS.	mm	mm	POS.	mm
LKF2	0.1875	LKA8	0.4375	LJD1	0.8000	LJA8	1.7500	0.065	LKHT	0.024	0.263	LJHT	0.095
LKD1	0.2000	MKD2	0.4500	LJD2	0.9000	MJD2	1.8000	0.071	LKGT	0.026	0.283	LJGT	0.103
LKD2	0.2250	MKD3	0.4750	LJD3	0.9500	MJD3	1.9000	0.077	LKFT	0.028	0.307	LJFT	0.111
LKD3	0.2375	MKA1	0.5000	LJA1	1.0000	MJA1	2.0000	0.084	LKET	0.030	0.334	LJET	0.121
LKA1	0.2500	MKD5	0.5500	LJD5	1.1000	MJD5	2.2000	0.092	LKDT	0.033	0.368	LJDT	0.134
LKD5	0.2750	MKA2	0.5625	LJA2	1.1250	MJA2	2.2500	0.097	LKCT	0.035	0.387	LJCT	0.141
LKA2	0.2812	MKA3	0.5937	LJA3	1.1875	MJA3	2.3750	0.102	LKBT	0.037	0.409	LJBT	0.148
LKA3	0.2968	MKD6	0.6000	LJD6	1.2000	MJD6	2.4000	0.115	LKAT	0.042	0.460	LJAT	0.167
LKD6	0.3000	MKA4	0.6250	LJA4	1.2500	MJA4	2.5000	0.131	MKHT	0.048	0.525	MJHT	0.191
LKA4	0.3125	MKD7	0.6500	LJD7	1.3000	MJD7	2.6000	0.141	MKGT	0.051	0.566	MJGT	0.206
LKD7	0.3250	MKA5	0.6875	LJA5	1.3333	MJA5	2.6666	0.153	MKET	0.056	0.613	MJET	0.223
LKA5	0.3437	MKD8	0.7000	LJA6	1.3750	MJA6	2.7500	0.167	MKDT	0.061	0.669	MJDT	0.243
LKD8	0.3500	MKA6	0.7500	LJA8	1.4000	MJA8	2.8000	0.184	MKCT	0.067	0.736	MJCT	0.267
LKA6	0.3750	MKA7	0.8125	LJA6	1.5000	MJA6	3.0000	0.194	MKBT	0.070	0.774	MJBT	0.281
MKD1	0.4000	MKA8	0.8750	MJD1	1.6000	MJA7	3.2500	0.204	MKBT	0.074	0.817	MJBT	0.297
LKA7	0.4062	LJF1	0.6666	LJA7	1.6250	MJA8	3.5000	0.230	MKAT	0.084	0.920	MJAT	0.334

1:1-LJD4

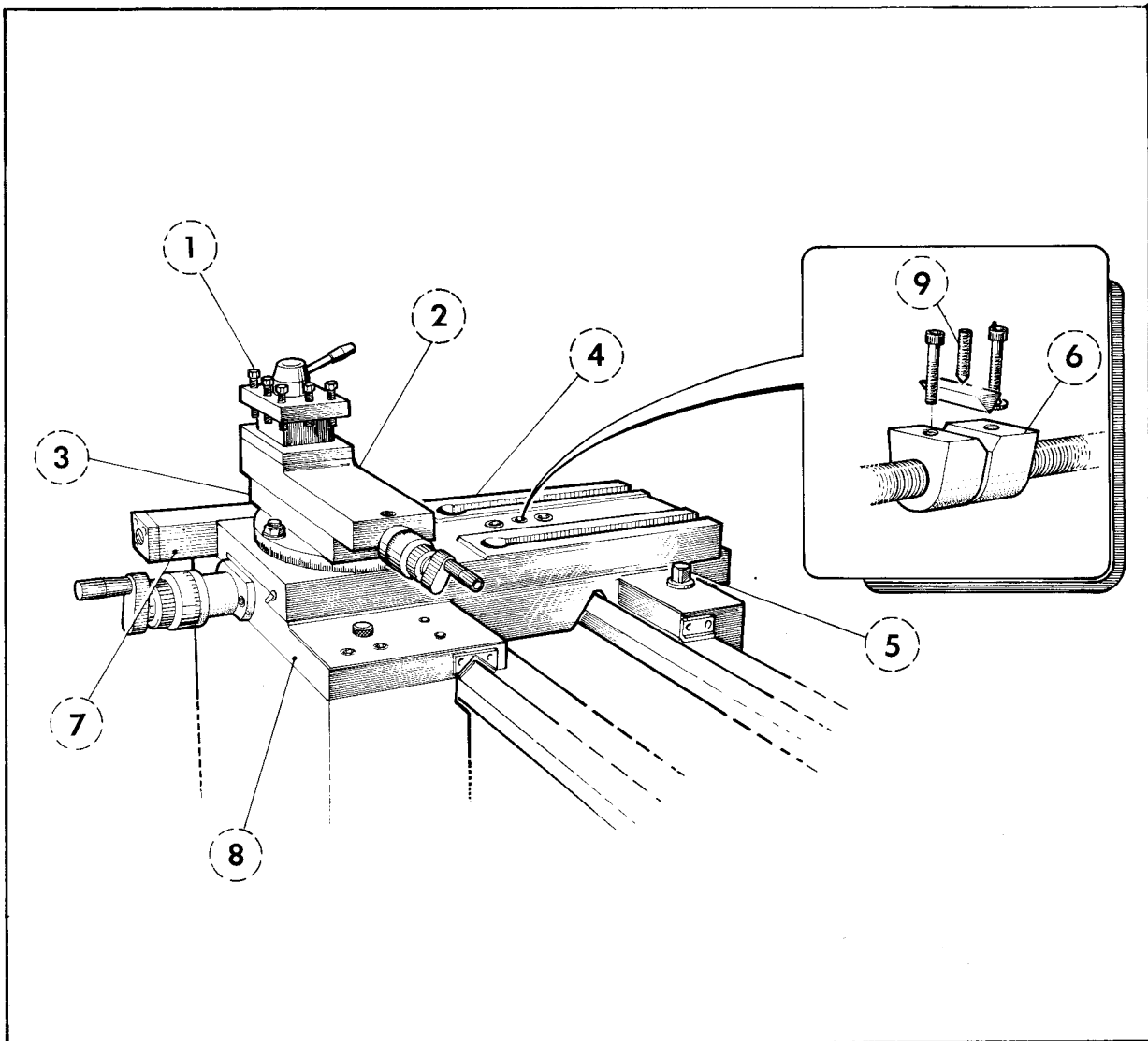

SADDLE

The saddle assembly consists of a toolpost (1), a top slide (2), a swivel slide (3), a cross slide (4), a device to automatic desengage of the transversal feed (7) and the housing of the saddle (8).

It was projected to offer easy handling that is smooth and precise.

To ensure precision readings on the cross slide dial, the nut (6) is special designed to eliminate all looseness, that is regulated through set screw (9).

Always, when turning faces, lock the saddle in its correct position using screw (5).

Give special attention to lubrication of the saddle, wich is done handle (see pag. 10).

APRON
(left hand)

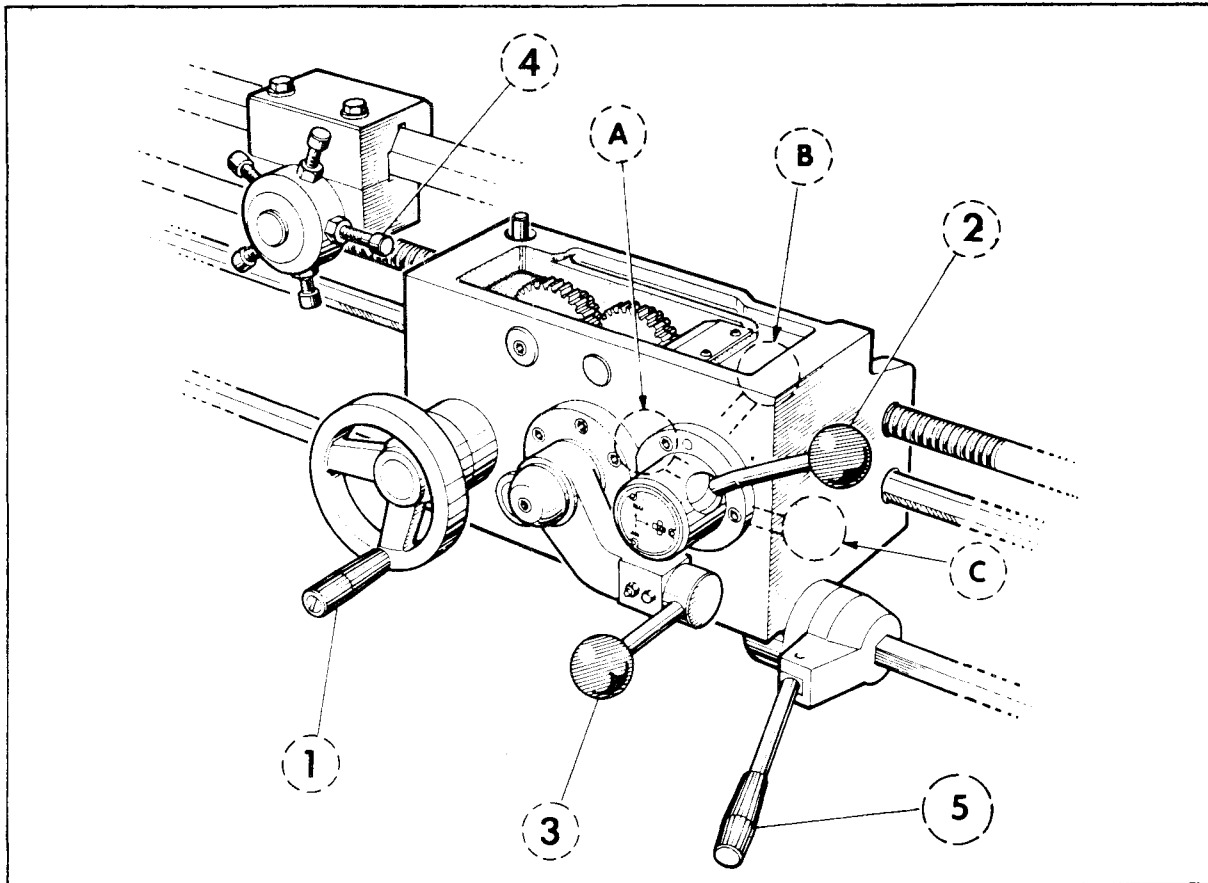

The apron is positioned manually by handwheel (1).

The longitudinal and transversal feeds and leadscrew nut are clamped using only one lever (2) in three positions.

Position A - Transversal feeds clamp.

Position B - Longitudinal feeds clamp.

Position C - Leadscrew nut clamp.

The automatic disengage or engage is done through the lever (3).

The lubrication is done by a pump located inside the apron, with oil reservoirs and channels distributed inside the box guaranteeing that every part of the set is perfectly lubricated.

Spindle rotation and neutral position are done through lever (5) with three positions:

Downward position - The spindle turns forward.

Upward position - The spindle turns backward.

Central position - The spindle remains stopped.

The bed stops (4) does the longitudinal automatic disengage system, which can be fitted at any position along the bed to be used in five stop positions.

APRON (right - hand)

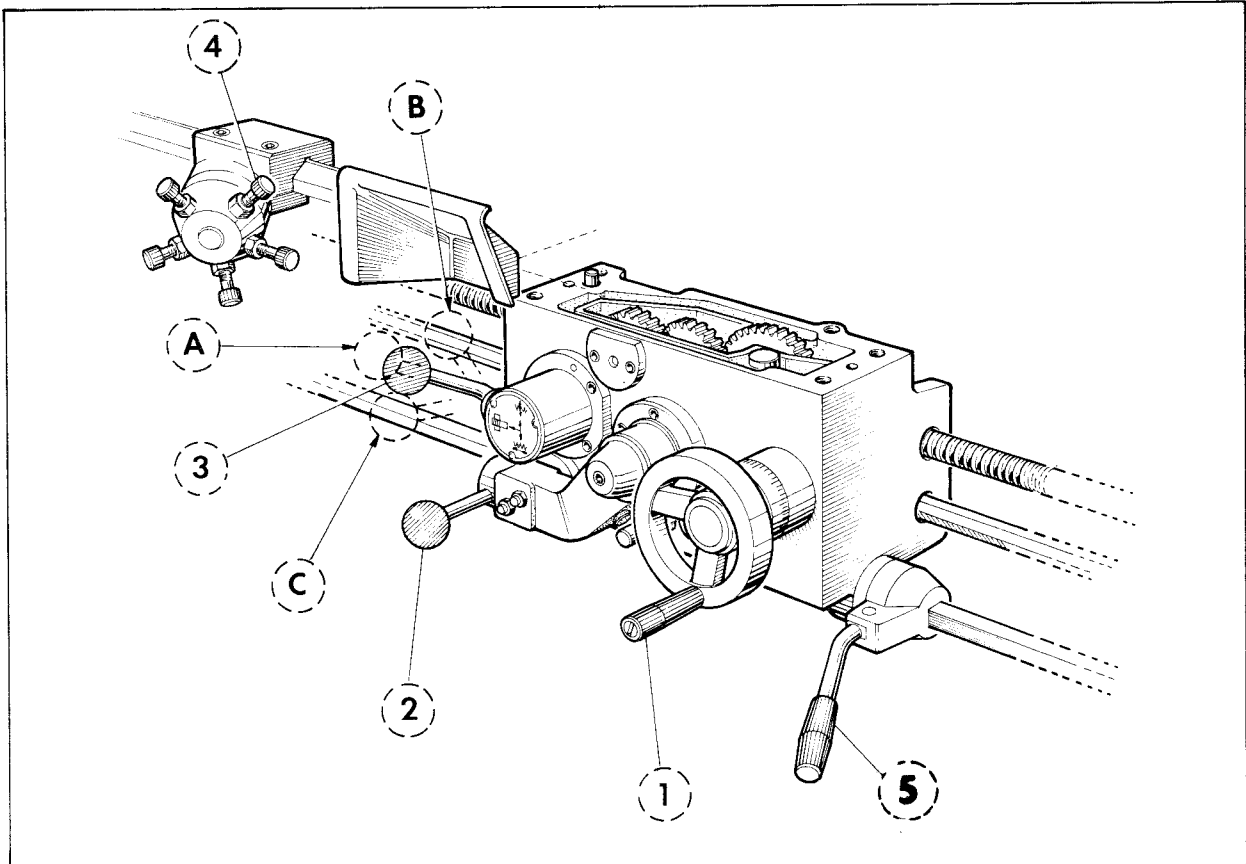

The apron is positioned manually by handwheel (1).

The longitudinal and transversal feeds and leadscrew nut are clamped using only one lever (3) in three positions.

Position A - Leadscrew nut clamp.

Position B - Transversal feeds clamp.

Position C - Longitudinal feeds clamp.

The automatic disengage or engage is done through the lever (2).

The lubrication is done by a pump located inside the apron, with oil reservoirs and channels distributed inside the box guaranteeing that every part of the set is perfectly lubricated.

Spindle rotation and neutral position are done through lever (5) with three positions:

Downward position - The spindle turns forward.

Upward position - The spindle turns backward.

Central position - The spindle remains stopped.

The bed stops (4) does the longitudinal automatic disengage system, which can be fitted at any position along the bed to be used in five stop positions.

TAILSTOCK

The tailstock is moved over the base manually and fixed by lever (1).

Center squaring and lateral displacement are made by leadscrew (4).

The index plate (3) provides a reading of the desired displacement. Each mark on the index plate corresponds to 1mm (0.039").

Before adjustment the tailstock must be loosened by turning of lever (1).

Barrel fixation is done by lever (2).

Lubrication of the screw and base is made at the lubrication points (5).

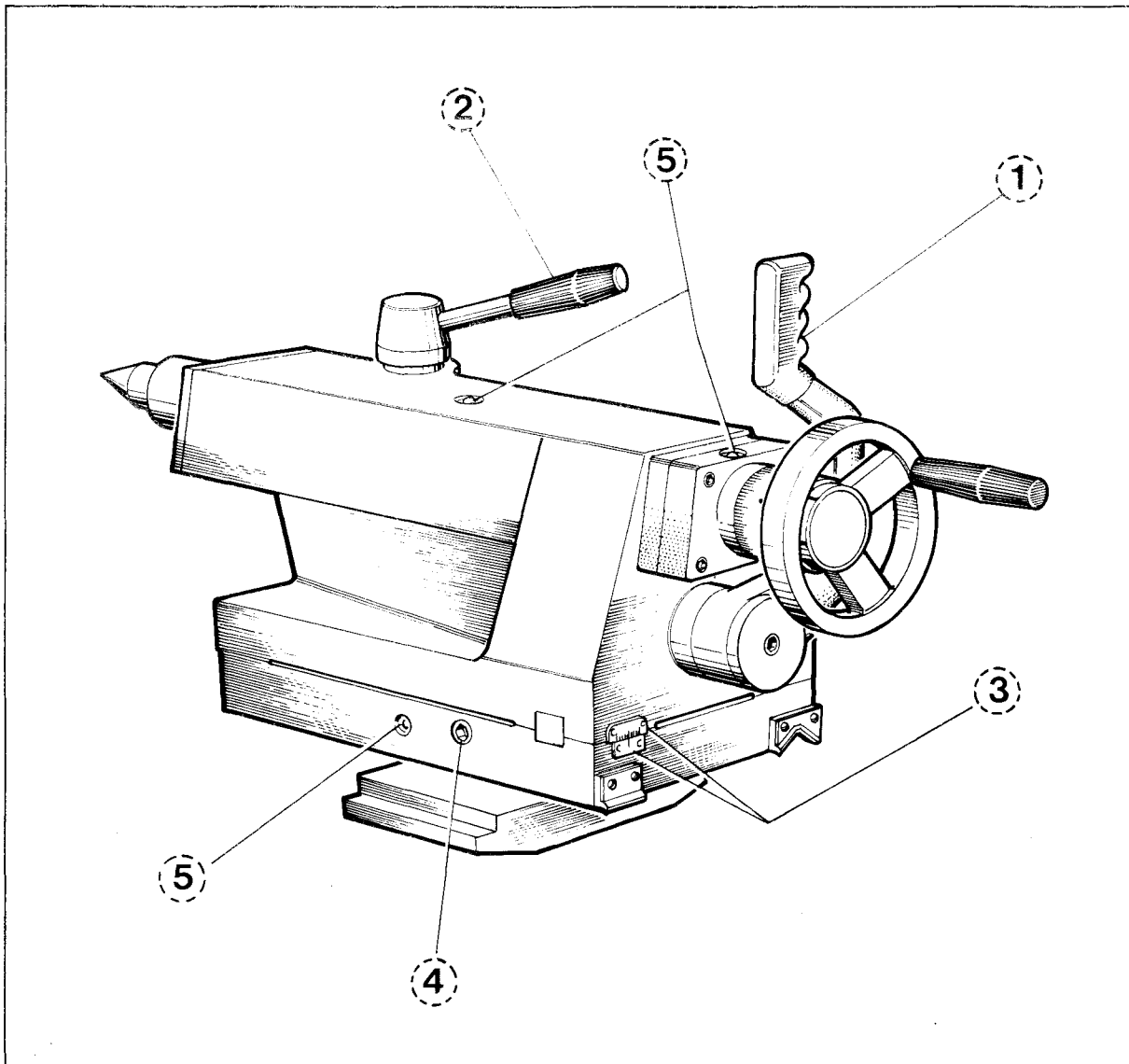

MOTOR DRIVING SYSTEM

The drive system consists of the motor, mounted on a base, supported by the axle and articulated over two screws that permit easy regulation of the drive belts.

The column points are reinforced by strong cording. Undesirable vibration is completely avoided when the motor is well balanced.

To adjust the drive belts, proceed in the following manner -

- Remove the covers (1) and (4).
- Loosen screw (3).
- Fasten screw (2) until the desired belt tension is achieved.

To verify correct belt tension, hold a ruler across space between the two sides of the belt. Press one half of the belt with the fingers. The belt should move 6 to 10mm (.25" to .40").

- Tighten screw (3).

The complete set of belt must be replaced when there is sufficient wear that the belts ride near the bottom of the pulley groove or are noticeably unequal in shape.

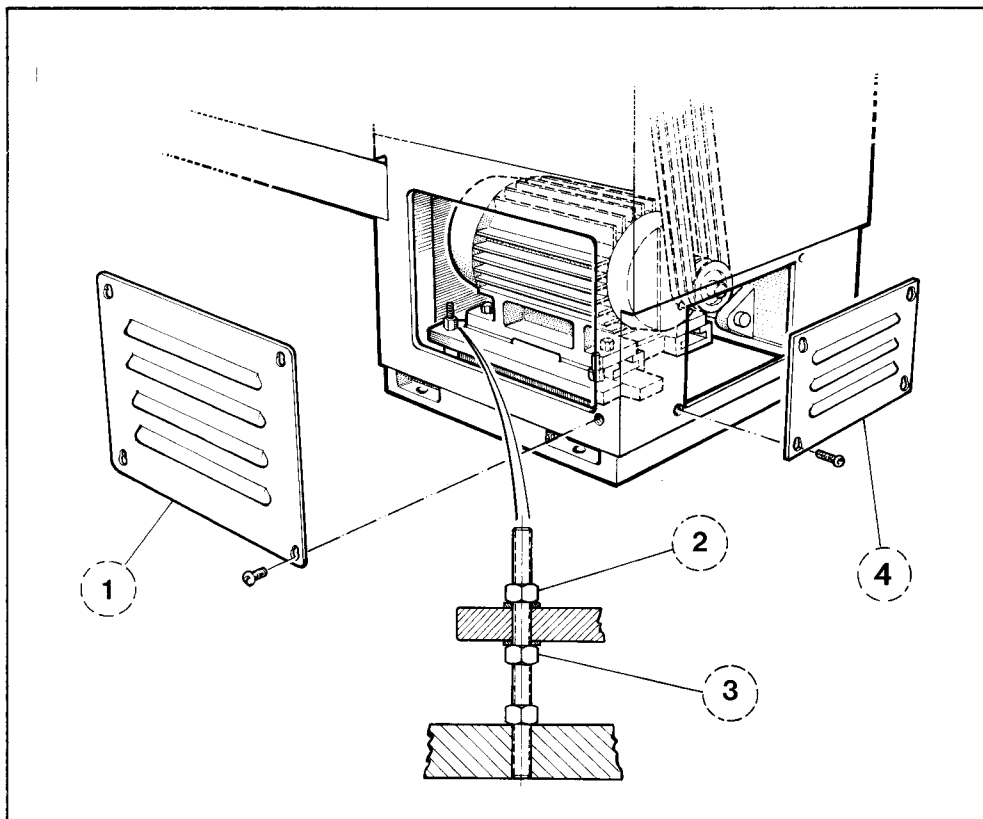

CHANGE GEAR

The change gear allows the operator to change or invert the position of the gears to obtain threads of Whitworth, Metric, Modular or Diametral Pitch. Instructions for mounting the change gears are on data plate of the threads-and-feeds gears box. After any change gears, the backlash must be .008" to .010" (.0,1 to 0,2mm).

CHANGE GEAR SAFETY PIN

To avoid possible damage when the machine is used improperly or with excessive loads, the assembly includes a safety pin (1) which breaks (in part "A") before the gears themselves are damaged.

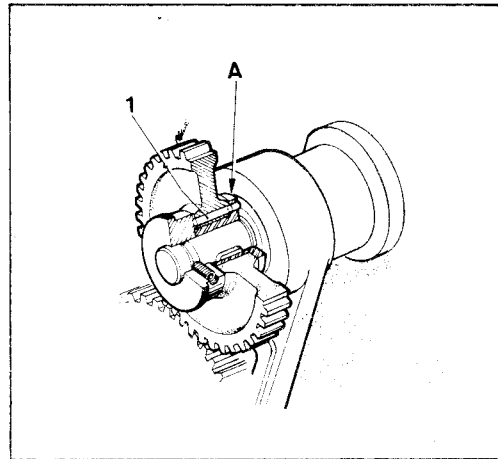

SAFETY COUPLING

A safety coupling is placed between the threads-and-feeds gear box transmission and the feeds shaft. Its function also is to avoid possible damage caused by excessive loads or improper use of the lathe.

FUNCTION

When an excessive force bears on the feeds shaft, wheel (4) yields and drives coupling (3) away from piece (2), stopping the transmission of force.

When the assembly is reset, coupling (3) join again, impelled by spring (4) and the connection is re-established.

An easier or more difficult clamp is obtained by loosening the leadscrew (1) and adjusting the ratchet protector (5).

For easier unclamping, tighten the ratchet protector. After adjustment, refasten the leadscrew (1).

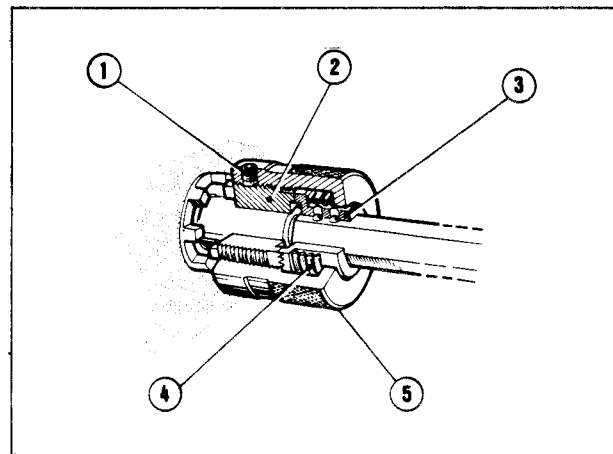

THREAD CUTTING INDICATOR DIAL
(leadscrew 4 TPI)

This assembly shows the clamp point of half-nut so that the starting point of each of the different pitch sizes is coincident with that of the first one.

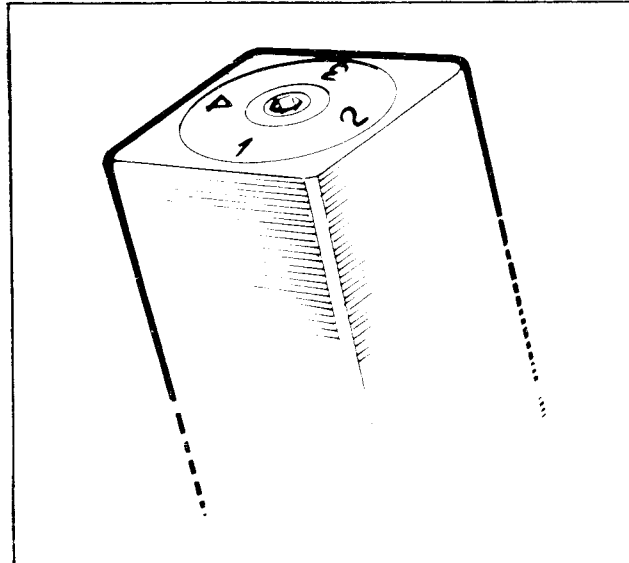

The dial indicator is divided into four numbered parts (1, 2, 3 and 4).

The example below shows how to use the dial —

PITCH	EXAMPLE	CLAMP POINT
Multiples of 4	4 - 8 - 12 - 16 - 20 - 24 - 28 - . . .	The half nut may be engaged at any point without using the dial.
Even pair pitches	4 - 6 - 8 - 10 - 12 - 14 - 16 - . . .	At any number on dial.
Odd pair pitches	5 - 7 - 9 - 11 - 13 - 15 - 17 - . . .	At two opposed numbers, 1-3 or 2-4
Half pitches	4.1/2" - 5.1/2" - 6.1/2" - . . .	At any number. Always use the same
Quarter pitches	4.3/4" - 5.3/4" - 6.3/4" - . . .	Do not unclamp the half nut screw

If the thread is Metric, Module or Diametral Pitch, the half-nut must remain engaged through the operation (until the end of the thread).

THREAD CUTTING INDICATOR DIAL (leadscrew pitch - 6mm)

This assembly shows the clamp point of the half-nut screw, so that the starting point of each of the different pitch sizes is coincident with that of the first one. The dial is divided into four numbered parts (1, 2, 3 and 4).

The example below shows how to use the dial.

THREADING DIAL INDICATOR - METRIC THREADS -		
Engage the indicator pinion with the leadscrew and tighten the nut to retain indicator in engagement. Release the nut, swing indicator out of engagement and retighten the nut when NOT REQUIRED.		
The following METRIC THREADS do not require DIAL INDICATOR: 0,075-0,1-0,125-0,15-0,2-0,25-0,3-0,4-0,5-0,6-0,75-1-1,5-2-3 and 6 mm.		
mm 	PINION	CLOSE THE LEADSCREW NUT AT...
0,8 4,0 1,2	16T	ANY LINE
0,225 0,450 4,500 9,000	24T	ANY LINE
8,000	16T	ANY NUMBERED LINE
1,250 2,500 5,000 10,000	20T	ANY NUMBERED LINE
0,175 0,350 0,700 1,750 3,500 7,000	14T	ONLY 1-3 or 2-4.
5,5	22T	ONLY 1-3 or 2-4.

If the thread is T.P.I., Modular or Diametral Pitch, the half-nut screw must remain engaged through the operation (until the end of the thread).

SPINDLE ADJUSTMENT

The spindle is mounted over precision conical bearings and gives the headstock exact and silent operation. After prolonged use, however, adjustment is required. Proceed in this way -

- Remove the spindle complement (1) and the cover (2).
- Loosen the cap screws (3).
- Adjust the bearings through nut (4).
- Tighten cap screws (3), locking the nut (4).
- Replace the spindle complement (1) and the cover (2).

Because the bearings are of high precision, we recommend that this operation be done only by qualified personnel.

NOTE - Excessive pressure on the bearings will cause serious damage. When the levers of the headstock are in the neutral position, the spindle must turn freely.

Axial clearance must be readjusted to easy pressure in the case of heating after the adjustment has been performed.

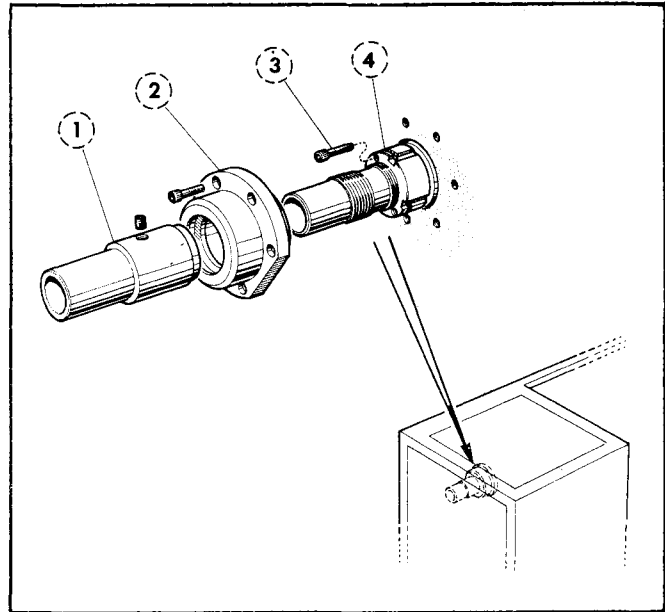

LEADSCREW AXLE ADJUSTMENT

Adjust the leadscrew axle as follows -

- Remove the cover (3)
- Loosen the trammel or washer (1)
- Adjust the leadscrew axial clearance by turning the nuts (2).
(This clearance must be measured using a precision comparator with magnetic base and a bearing ball. Apply a little grease, then fix the ball on the leadscrew point. Turn the spindle and press the comparator. The axial clearance must be a maximum of 0.01mm).

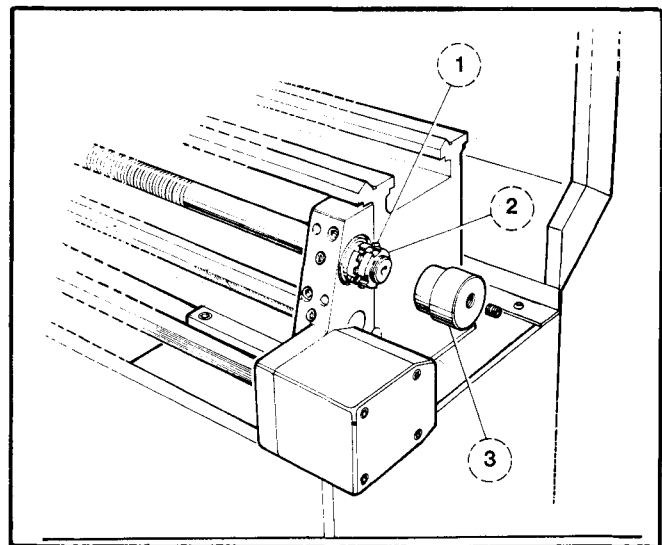

- Replace the cover (3)

BRAKE SYSTEM

Spindle rotation command is made by using lever located at the right end of apron.

Reverse or forward rotation is obtained moving lever up or down.

The Electromagnetic Brake is automatically energized when this lever is placed on, or passes through the central position.

When stoping the spindle by placing lever on its central position the brake is energized and after the spindle is completely stoped, the brake is desenergized.

The reversion of spindle is made through the lever without stoping in its central position because the RELAY/SENSOR of moving, free the selected revolution direction after total spindle tops.

HOW TO ADJUST THE SENSOR'S POSITION

To adjust the SENSOR/RELAY of moving system (see electrical diagram) follow the instructions:

- A – Verify the SENSOR A2 (1) alignment in relation to the pulley hole (2) ($\varnothing 18\text{mm} \times 1,5\text{mm}$ deep).
- B – Put the spindle in motion (any speed).
- C – Loose the nuts (3) and aproximate carefully the SENSOR to the Pulley until that the LED of the RELAY (A1) turn "OFF". Make note on the sensor's position.
- D – Move back the SENSOR carefully (the LED will be "ON" again) until that the LED turn "OFF" again. Make note on the sensor's position.
- E – Fix the SENSOR between the two position obtained in "C" and "D"

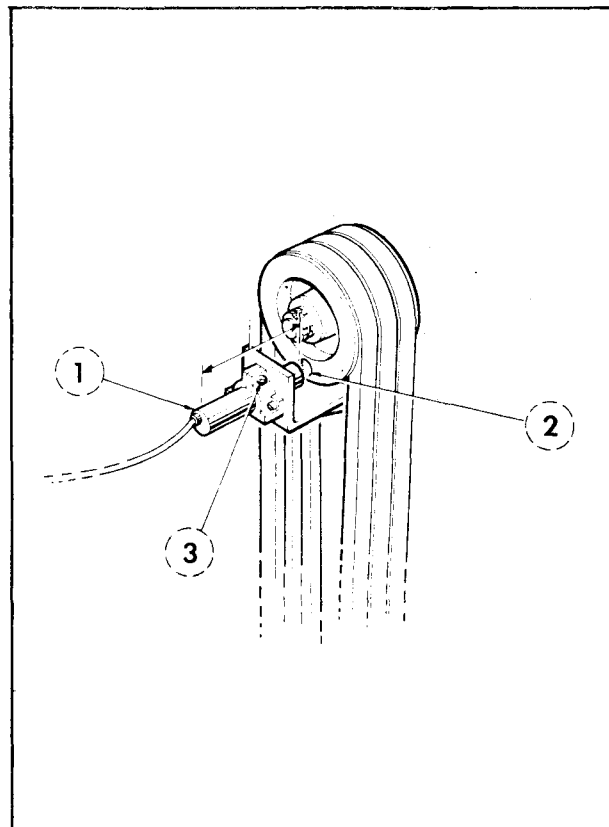

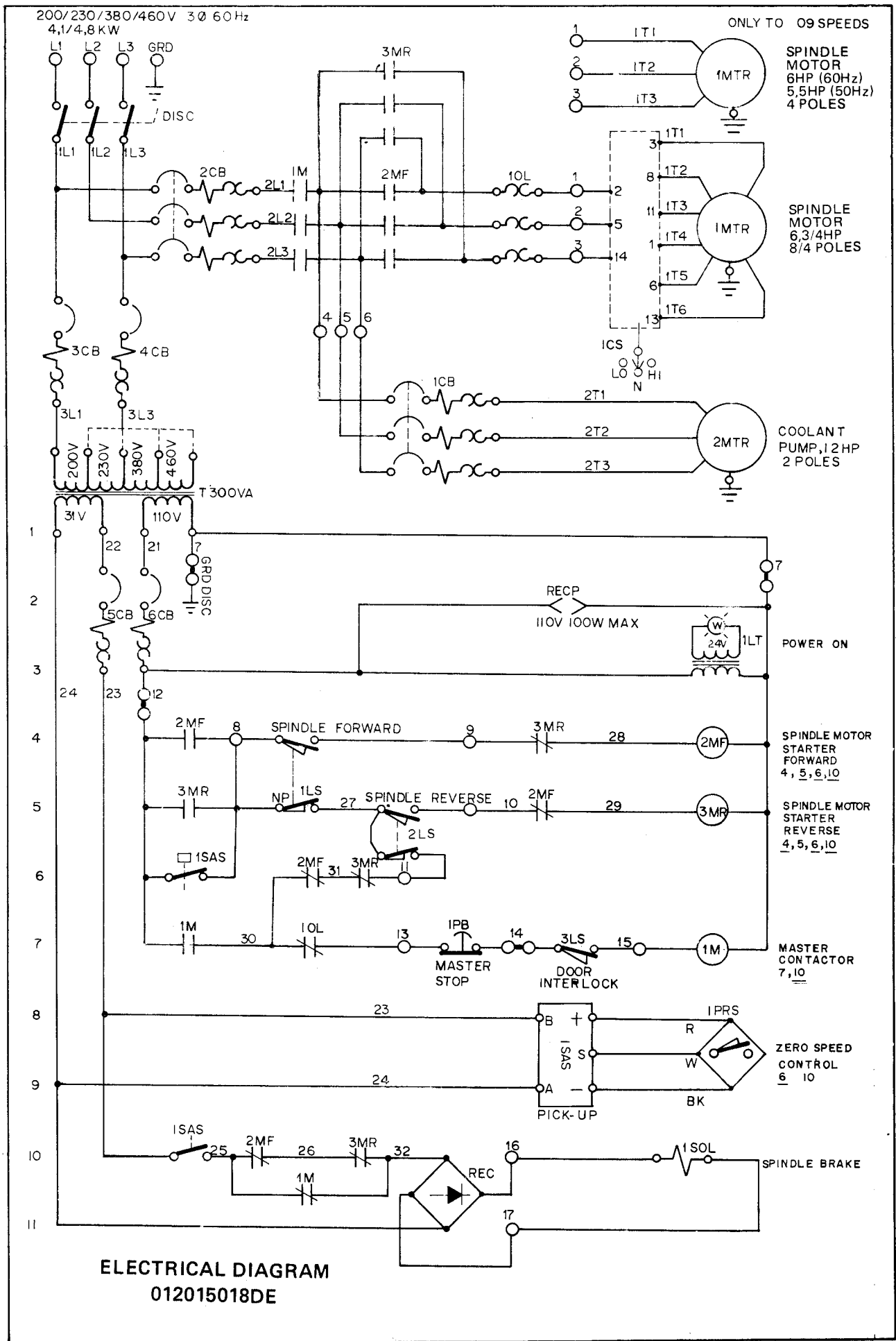

PARTS LIST

Spare parts orders can be answered quickly and correctly if the following information is provided:

- Lathe's model

- Lathe's serial number (it is written on the back part of the bed)

- Name, reference and number of the piece

- Quantity of pieces desired

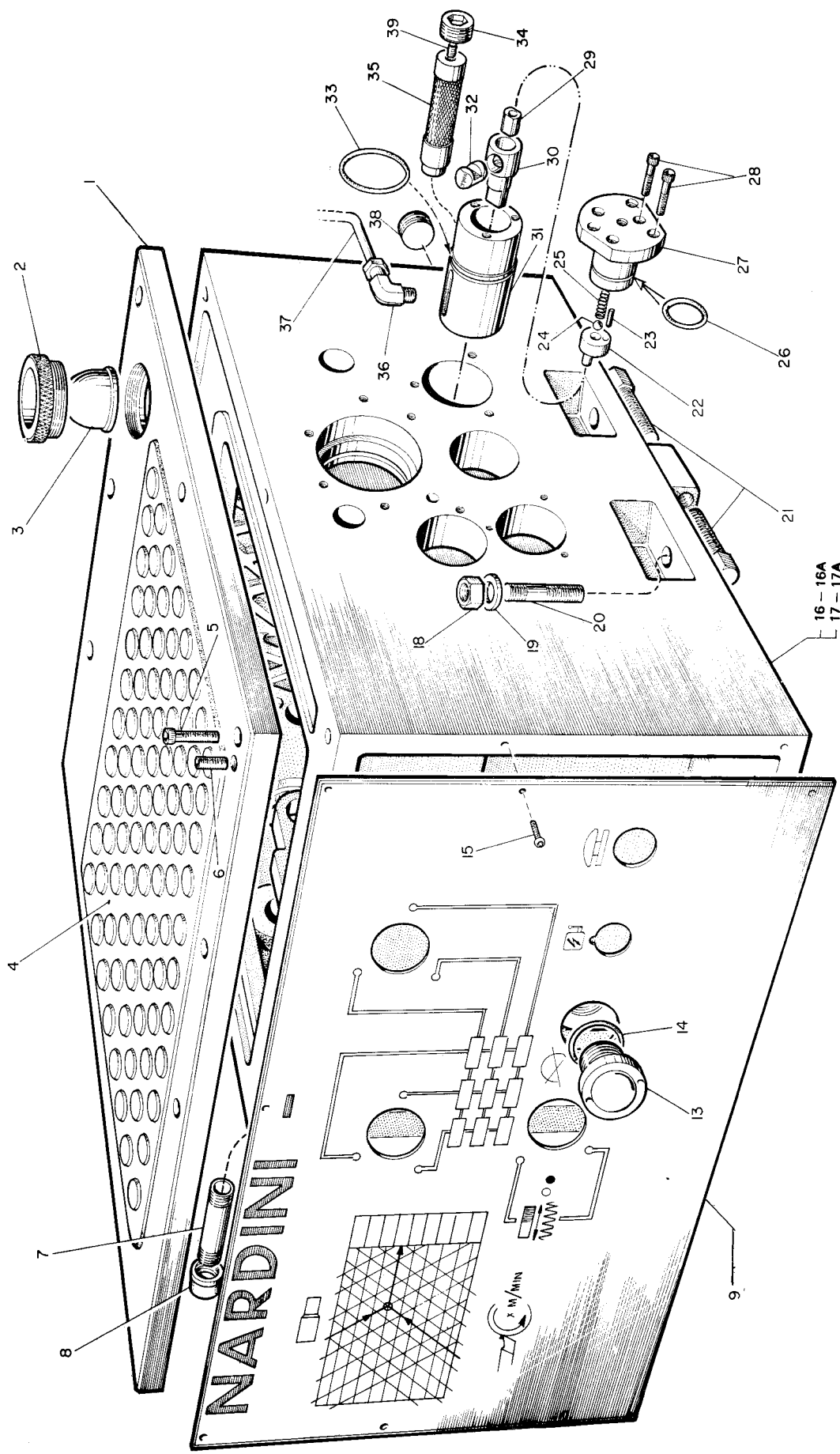

MS-MI-401C

HEADSTOCK MS-MI-401C

REF. NUMBER	NAME	REF. NUMBER	NAME	REF. NUMBER	NAME
1	012001003	Cover	17	012001002	Casting (spindle bore - 46 and
2	012001060	Nut			42mm)**
3	001118040	Oil sight	17A	012001134	Casting (spindle bore - 52mm)**
4	012001080	Shield	18	001012112	Nut
5	001001208	Cap screw (M8x25)	19	001014015	Washer
6	001008410	Set screw (M10x20)	20	001024306	Stud
7	012001077	Drain pipe	21	012001059	Pin
8	001207003	Elbow	22	012001086	Wheel pin
9	012001123	Data plate ***	23	001020355	Pin (4x12)
13	001118010	Oil sight	24	001127030	Ball (6,5)
14	001133117	Oil ring	25	001117052	Spring
15	001036154	Cap screw (M3x8)	26	001133122	Oil ring
16	012001001	Casting (spindle bore - 46 and	27	012001058	Cover
		42mm)*	28	001001156	Cap screw (M8x16)
16A	012001133	Casting (spindle bore - 52mm)*	29	012001083	Bushing
			30	012001052	Shaft
			31	012001048	Pump housing
			32	012001084	Impeller pin
			33	001133227	Oil ring
			34	001205007	Plug
			35	012001117	Oil filter
			36	001254005	Connector
			37	001263103	Pipe
			38	001205005	Plug
			39	001008407	Set screw (M10x10)

* Models MS-1400 S/E and MS-175 S/E

** Models MS-1600 S/E and MS-205 AS/AE

*** When asking this part, specify the model and between centers.

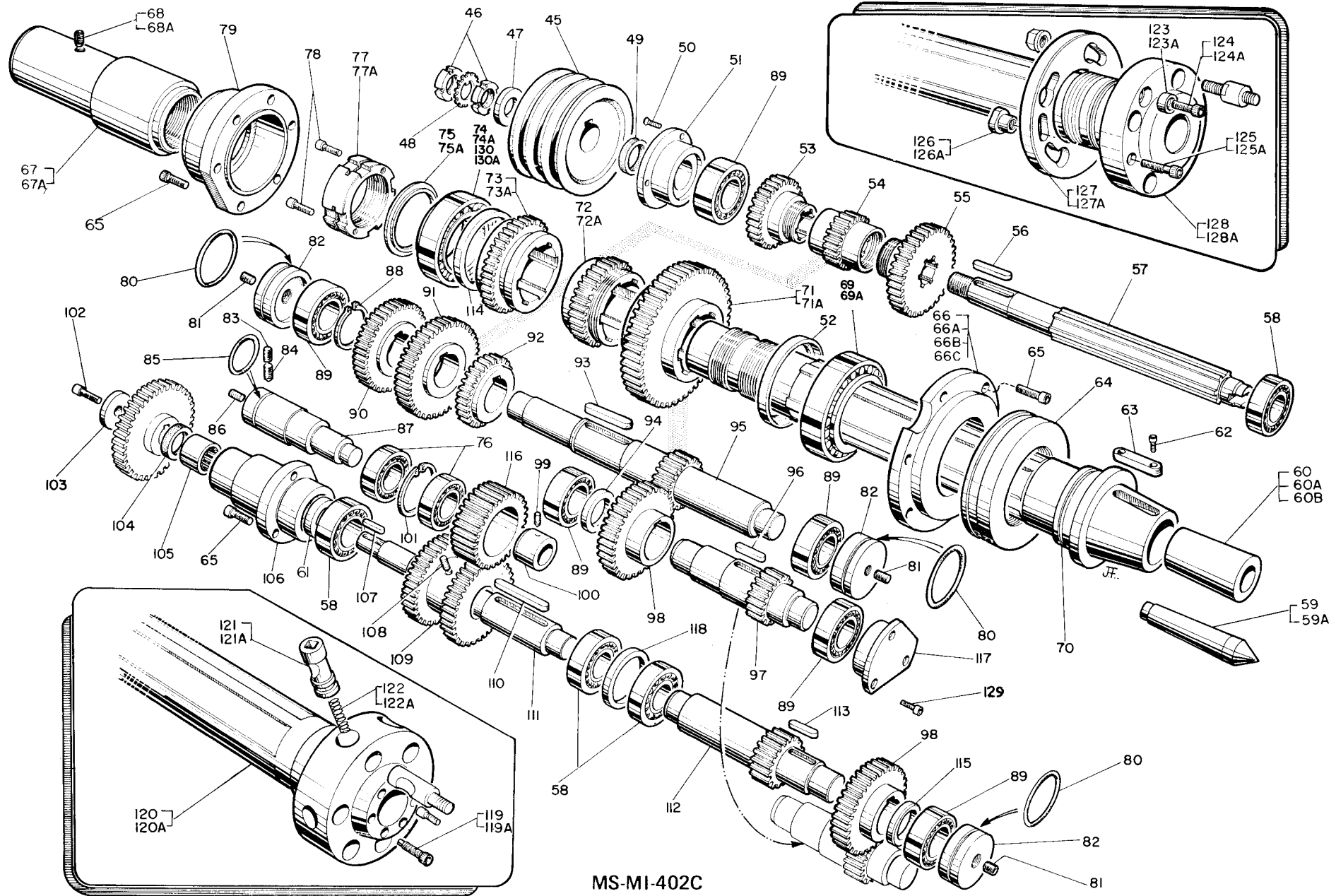

MS-MI-402C

HEADSTOCK MS-MI-402C

REF.	NUMBER	NAME	REF.	NUMBER	NAME	REF.	NUMBER	NAME
45	012001126	Pulley	75A	014001045	Collar**	116	012001006	Gear Z =40
46	001030005	Lock nut KM-4	76	001300053	Bearing 6006	117	014001018	Cover
47	001014019	Washer	77	012001122	Nut*	118	012001019	Spacer
48	001031005	Lock washer MB - 4	77A	014001044	Nut**	129	001001156	Cap screw (M8x16)
49	001113056	Oil seal	78	001001106	Cap screw (M5x20)	130	001316017	Bearing TIMKEN (cone)**
50	001002106	Cap screw (M6x16)	79	012001074A	Rear Cover	130A	001316317	Bearing TIMKEN (cup)**
51	012001127	Cover	80	001133227	Oil ring	SPINDLE NOSE CAMLOCK D1-5 (Spindle bore - 46mm)(1.21/32")		
52	013001016	Clipping	81	001008357	Set screw (M8x10)			
53	012001042	Gear Z =36	82	012001018	Cover	119	001016011	Cam screw
54	012001033	Gear Z =27	83	001008359	Set screw (M8x16)	120	012001112A	Spindle
55	012001032	Gear Z =46	84	001009359	Set screw (M8x16)	121	001107034	Cam
56	001023161	Key	85	001133125	Oil ring	122	001117085	Cam spring
57	012001125	Shaft	86	001008459	Set screw (M12x16)	SPINDLE NOSE CAMLOCK D1-6 (Spindle bore - 52mm)(2.1/32")		
58	001300049	Bearing 6305	87	012001010	Shaft			
59	001121004	Center *	88	001033031	Snap ring (38)	119A	001016012	Cam screw
59A	001121005	Center **	89	001300054	Bearing 6206	120A	014001039A	Spindle
60	012001088	Conical bushing (ASA - DIN)*	90	012001030	Gear Z =45	121A	001107035	Cam
60A	012001085	Conical bushing (CAMLOCK)*	91	012001029	Gear Z =54	122A	001107141	Cam spring
60B	014001046	Conical bushing (CAMLOCK,DIN)**	92	012001031	Gear Z =35	SPINDLE NOSE DIN 55022 - 5 (Spindle bore - 46mm)(1.13/16")		
61	013001025	Clipping	93	001023214	Key			
62	001028204	Cap screw (3/16"Wx3/8')(ASA)*	94	012001013	Spacer	123	001107012	Drag pin
63	001016002	Key (ASA)*	95	012001039	Gear shaft	124	001001156	Cap screw (M6x16)
64	012001070	Chuck nut (ASA)*	96	001023210	Key	125	001001158	Cap screw (M6x25)
65	001001157	Cap screw (M6x20)	97	012001011	Gear Z =19	126	001107113	Nut
66	012001110	Cover (ASA)*	98	012001005	Gear Z =38	127	001107103	Collar
66A	012001111	Cover (CAMLOCK and DIN)*	99	001009359	Set screw (M8x20)	128	012001108A	Spindle
66B	012001120	Cover (CAMLOCK)**	100	012001014	Bushing	SPINDLE NOSE DIN 55022 - 6 (Spindle bore - 52mm)(2.1/32")		
66C	013001024	Cover (DIN)**	101	001034036	Snap ring (55)			
67	012001121	Spindle extention*	102	001001207	Cap screw (M8x20)	123A	001107013	Drag pin
67A	012001132	Spindle extention**	103	012001026	Washer	124A	001001207	Cap screw (M7x16)
68	001010356	Set screw (M8x10)*	104	001113144	Oil seal	125A	001001209	Cap screw (M6x25)
68A	001010357	Set screw (M8x12)**	105	001309038	Bearing NKI 22/20	126A	001107114	Nut
69	001316022	Bearing TINKEN	106	012001028	Bearing flanged housing	127A	001107104	Collar
69A	001316322	Bearing TIMKEN (cup)*	107	001023106	Key	128A	014001065	Spindle
70	012001109A	Spindle (ASA)*	108	001009409	Set screw (M10x16)	* Spindle bore - 46mm (1.13/16") or 42mm (1.21/32")		
71	012001004	Gear Z =57*	109	012001025	Double gear			
71A	014001042	Gear Z =57 **	110	001023215	Key	** Spindle bore - 52mm (2.1/32")		
72	012001012	Gear Z =41*	111	012001021	Shaft			
72A	014001041	Gear Z =41**	112	012001022	Gear shaft	Spindle nose ASA LO - Spindle bore 46mm (1.13/16")		
73	012001024	Gear Z =48*	113	001023210	Key			
73A	014001040	Gear Z =48**	114	013001005	Clipping			
74	001316015	Bearing TIMKEN (cone)*	115	012001020	Spacer			
74A	001316315	Bearing TIMKEN (cup)*						
75	012001072	Collar*						

35

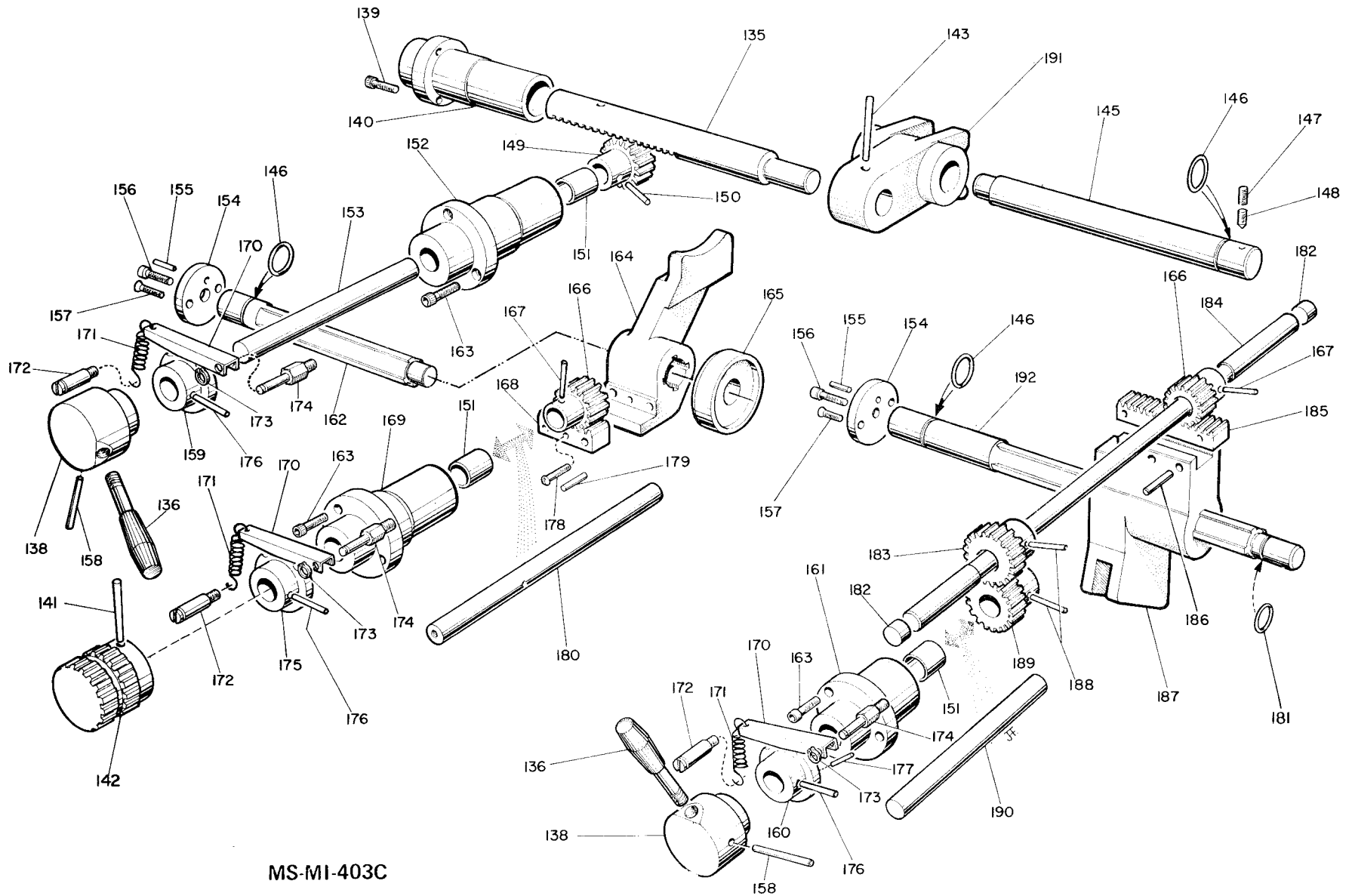

MS-MI-403C

HEADSTOCK MS-MI-403C

REF.	NUMBER	NAME	REF.	NUMBER	NAME	REF.	NUMBER	NAME
135	012001046	Rack shaft	155	001021256	Split pin (4x14)	174	012001055	Shaft
136	001112010	Handle	156	001001207	Cap screw (M8x20)	175	012001045	Ratchet
138	012001091	Handle sleeve	157	001002106	Cap screw (M6x16)	176	001021316	Split pin (5x36)
139	001001157	Cap screw (M6x20)	158	001017417	Taper pin (5x55)	177	001021206	Split pin (3x14)
140	012001047	Cover	159	012001090	Ratchet	178	001003158	Cap screw (M6x25)
141	001017416	Taper pin (5x50)	160	012001089	Ratchet	179	001021315	Split pin (5x32)
142	016005084	Handle	161	012001095	Flanged bushing	180	012001094	Shaft
143	001018008	Taper pin (5x45)	162	012001007	Shaft	181	001133113	Oil ring
144	013001026	Collar	163	001001156	Cap screw (M6x20)	182	012001079	Plug
145	012001008	Shaft	164	012001027	Shifting fork	183	012001036	Gear Z=22
146	001133115	Oil ring	165	012001015	Spacer	184	012001034	Shaft
147	001008358	Set screw (M8x12)	166	012001035	Gear Z=15	185	012001051	Rack
148	001009358	Set screw (M8x12)	167	001021311	Split pin (5x24)	186	001021314	Split pin (5x30)
149	012001087	Gear Z=18	168	012001050	Rack	187	012001017	Shifting fork
150	001021313	Split pin (5x28)	169	012001097	Flanged bushing	188	001021315	Split pin (5x32)
151	001114156	Bushing	170	012001057	Ratchet guide	189	012001040	Gear Z=20
152	012001096	Flanged bushing	171	001116100	Spring	190	012001092	Shaft
153	012001093	Shaft	172	012001056	Shaft	191	012001023	Shifting fork
154	012001016	Flange	173	001033003	Snap ring (5)	192	012001049	Shaft

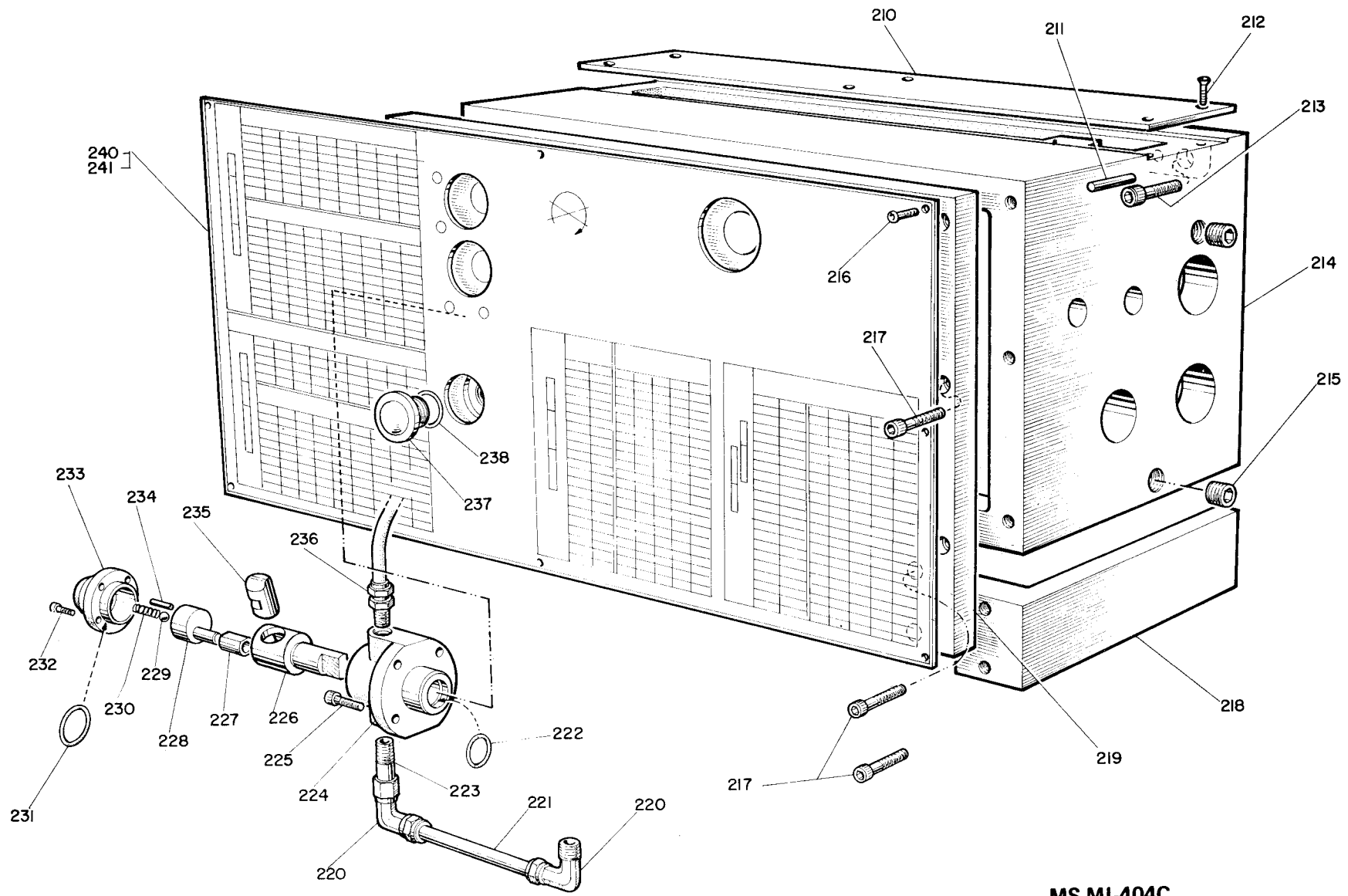

MS-MI-404C

GEAR BOX MS-MI-404C

REF. NUMBER	NAME	REF. NUMBER	NAME	REF. NUMBER	NAME			
210	012005019	Cover	221	001231005	Pipe (nylon)	232	001007358	Cap screw (M4x12)
211	001018005	Taper pin (6x32)	222	001133013	Oil ring	233	012005093	Cover
212	001013406	Cap screw (M5x10)	223	012005097	Connector	234	001021255	Split pin (4x12)
213	001001259	Cap screw (M10x25)	224	012005092	Pump housing	235	012001084	Impeller pin
214	012005001	Casting	225	001001160	Cap screw (M6x35)	236	001227013	Connector
215	001205003	Plug	226	012001052	Shaft	237	001118010	Oil sight
216	001036154	Cap screw (M3x8)	227	012001083	Bushing	238	001133117	Oil ring
217	001001156	Cap screw (M6x16)	228	012001086	Wheel pin	240	012005096	Data plate (leadscrew pitch - 4 TPI)
218	012005072	Cover	229	001127030	Ball	241	012005088A	Data plate (leadscrew pitch - 6mm)
219	012005002	Cover	230	001117052	Spring			
220	001229012	Connector	231	001133019	Oil ring			

63

MS-MI-405C

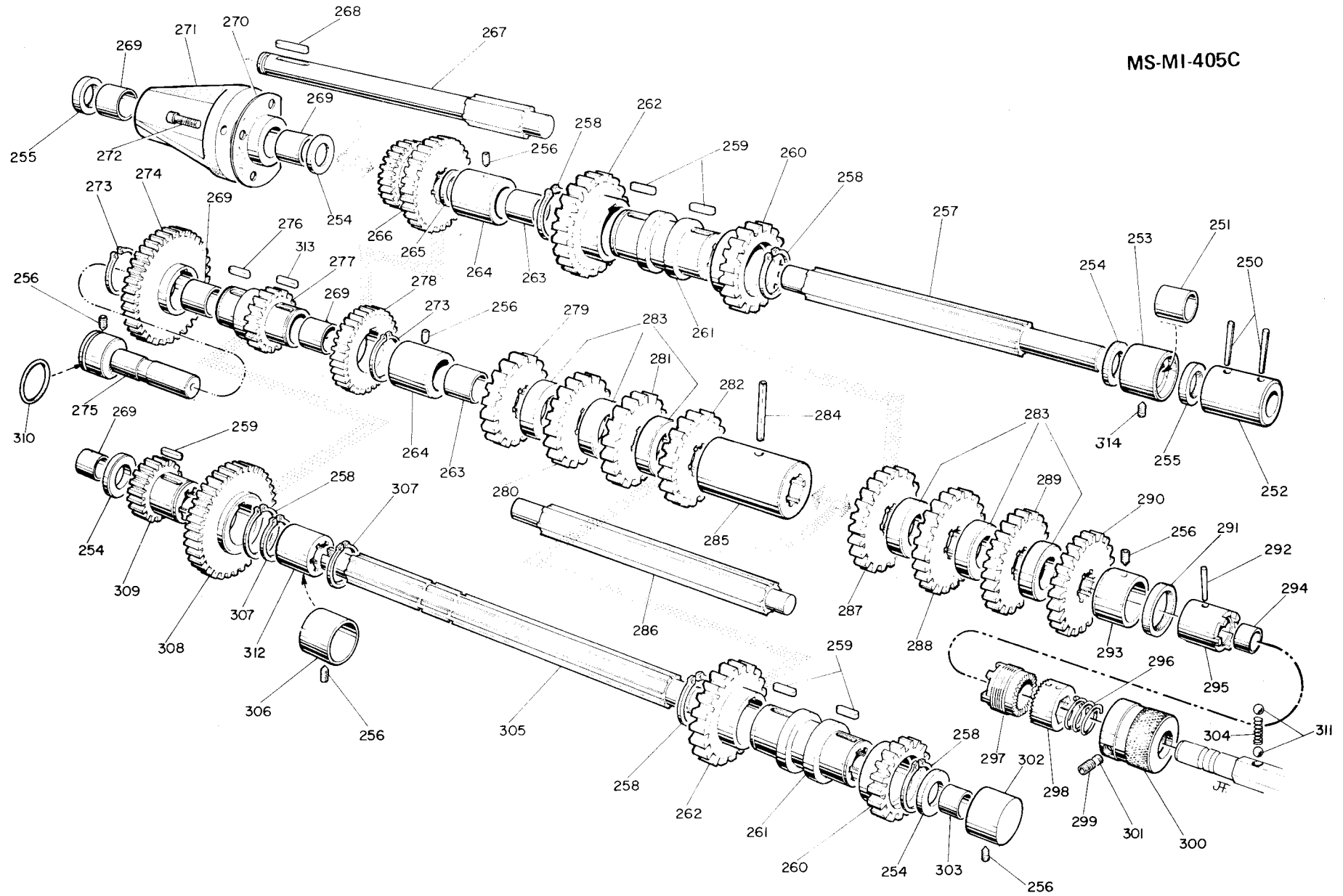

GEAR BOX MS-MI-405C

REF. NUMBER	NAME	REF. NUMBER	NAME	REF. NUMBER	NAME			
250	001017413	Taper pin (5x36)	271	012005005	Flanged bearing	292	001017410	Taper pin (5x28)
251	001114257	Bushing	272	001001156	Cap screw (M6x16)	293	012005051	Bushing
252	012005044	Sleeve	273	001033028	Snap ring (34)	294	012005050	Bushing
253	012005043	Bushing	274	012005025	Gear Z=44	295	012005049	Clutch
254	012005022	Washer	275	012005009	Shaft	296	001117490	Spring
255	005.05 BR	Oil seal	276	012005023	Key	297	012005048	Clutch
256	001009307	Set screw (M6x10)	277	012005010	Gear Z=22	298	012005046	Clutch
257	012005004	Shaft	278	012005026	Gear Z=33	299	001008305	Set screw (M6x16)
258	001033030	Snap ring (36)	279	012005037	Gear Z=16	300	012005047	Clamp bushing
259	001023104	Key	280	012005036	Gear Z=18	301	012005045	Contact point
260	012005042	Gear Z=20	281	012005040	Gear Z=19	302	012005027	Bushing
261	012005014	Spacer	282	012005038	Gear Z=20	303	001114255	Bushing
262	012005041	Gear Z=20	283	012005039	Spacer	304	001117045	Spring
263	001114258	Bushing	284	001021318	Split pin (5x45)	305	012005011A	Bushing
264	012005030	Bushing	285	012005031	Spacer	306	012005063	Bushing
265	012005029	Spacer	286	012005013	Shaft	307	001033022	Snap ring (25)
266	012005008	Double gear Z=22 - Z=33	287	012005032	Gear Z=22	308	012005028	Gear Z=44
267	012005007	Shaft	288	012005033	Gear Z=24	309	012005012	Gear Z=22
268	001023110	Key	289	012005034	Gear Z=26	310	001133125	Oil ring
269	001114256	Bushing	290	012005035	Gear Z=28	311	001127030	Ball (6,5)
270		Gasket	291	015.35 BR	Oil seal Sabo	312	012005064	Sleeve
						313	012005024	Key
						314	001009305	Set screw (M6x6)

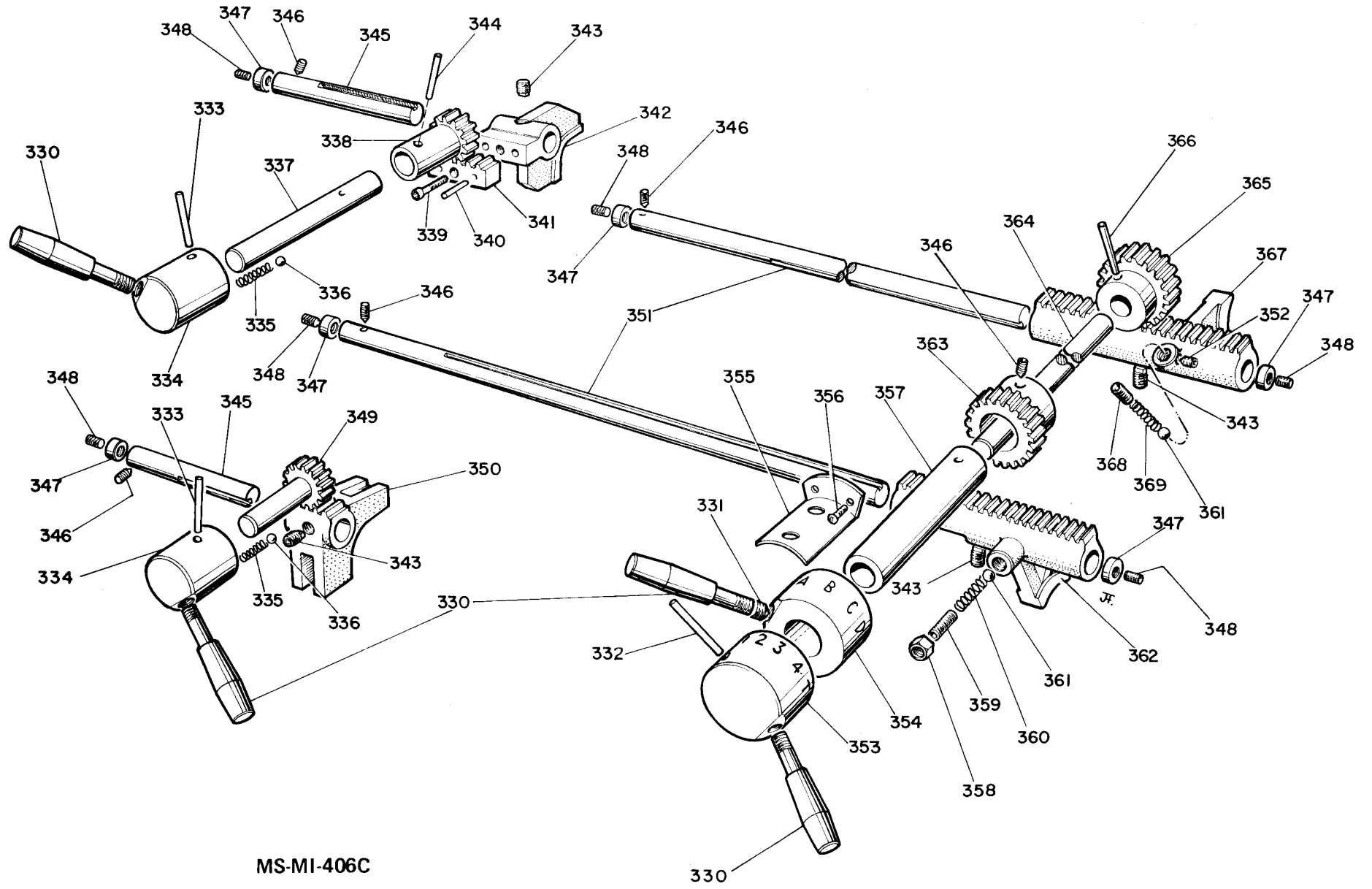

MS-MI-406C

GEAR BOX MS-MI-406C

REF. NUMBER	NAME	REF. NUMBER	NAME	REF. NUMBER	NAME			
330	001112010	Lever	343	012005061	Set screw	356	001036155	Cap screw (M3x10)
331	001009356	Set screw (M8x8)	344	001021311	Split pin (5x24)	357	012005073	Bushing
332	001017418	Taper pin (5x60)	345	012005020	Shaft	358	001012002	Nut
333	001017414	Taper pin (5x40)	346	001009307	Set screw (M6x10)	359	001008408	Set screw (M10x12)
334	012005085	Handle boss	347	012005021	Cover	360	001117080	Spring
335	001117050	Spring	348	001008306	Set screw (M6x18)	361	001127040	Ball (8)
336	001127030	Ball (6,5)	349	012005071	Gear Z =14	362	012005016	Shifting fork
337	012005067	Shaft	350	012005018	Shifting fork	363	012005074	Gear Z =26
338	012005066	Gear Z =15	351	012005062	Shaft	364	012005068	Shaft
339	001001056	Cap screw (M4x16)	352	001008256	Set screw (M4x8)	365	012005075	Gear Z =26
340	001021261	Split pin (4x24)	353	012005086	Selection ring	366	001021316	Split pin (5x36)
341	012005065	Rack	354	012005084	Selection ring	367	012005017	Shifting fork
342	012005006	Shifting fork	355	012005078	Window bracket	368	001008407	Set screw (M10x10)
						369	001117075	Spring

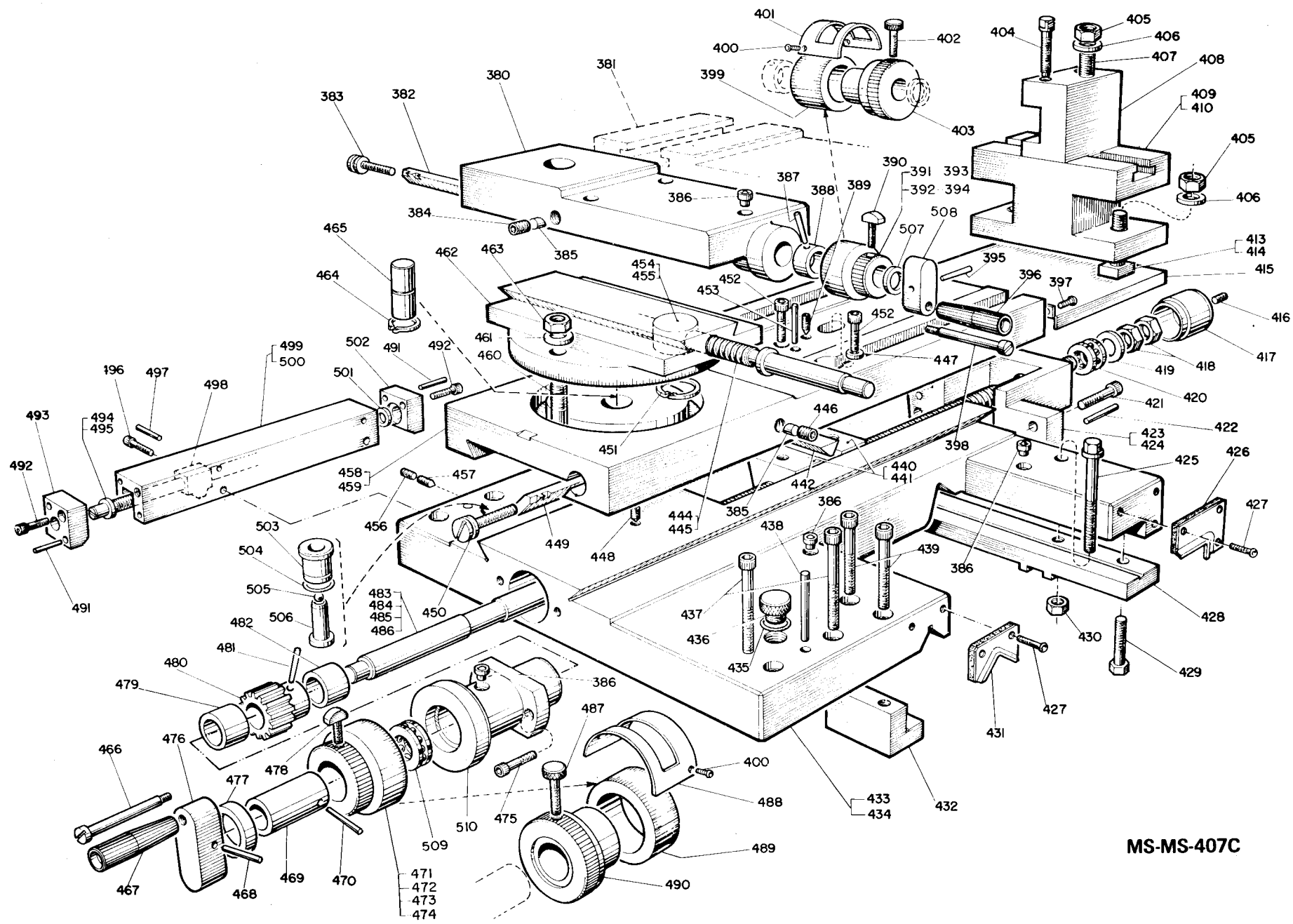

MS-MS-407C

SADDLE MS-MI-407C

REF.	NUMBER	NAME	REF.	NUMBER	NAME	REF.	NUMBER	NAME
380	012006104	Top slide	425	012006019	Screw	470	001017412	Taper pin (5x32)
381	012006105	Top slide ("T")	426	012006006	Wiper	471	012006111	Indexing ring (1 div. =0,025mm)
382	012006026	Gib	427	001003105	Set screw (M5x12)	472	012006112	Indexing ring (inch)
383	012006065	Adjusting screw	428	012006007	Strip	473	012006154	Indexing ring (1 div. =0,02mm)
384	001008407	Set screw (M10x10)	429	001004359	Hexagonal head screw (M8x25)	474	012006155	Indexing ring (1 div. =0,05mm)
385	012006115	Contact point	430	001012111	Nut	475	001001158	Cap screw (M6x25)
386	001122001	Oiler	431	012006035	Wiper	476	001129014A	Handle
387	001017359	Taper pin (4x26)	432	012006124	Strip	477	012006114	Spacer
388	012006025	Collar	433	012006101	Casting *	478	013006023A	Checking bolt
389	001009310	Set screw (M6x20)	434	012006136	Casting **	479	012006139	Spacer (MS-205 and MS-1600) **
390	013003025A	Checking bolt	435	001133012	Oil ring	480	015006026	Gear Z =14
391	012006122	Indexing ring (1 div. =0,025mm)	436	013006042	Plug	481	001017409	Taper pin (5x26)
392	012006123	Indexing ring (inch)	437	001001261	Cap screw (M10x40)	482	012006116	Bushing
393	012006152	Indexing ring (1 div. =0,02mm)	438	001017417	Taper pin (5x55)	483	012006140	Saddle leadscrew (mm) **
394	012006153	Indexing ring (1 div. =0,05mm)	439	001001211	Cap screw (M8x40)	484	012006141	Saddle leadscrew (inch) **
395	001017356	Taper pin (4x22)	440	012006109	Nut (mm)	485	012006107	Saddle leadscrew (mm) *
396	001109004	Handle	441	012006110	Nut (inch)	486	012006108	Saddle leadscrew (inch) *
397	001003104	Cap screw (M5x10)	442	012006033	Wedge	487	012006147	Checking bolt ***
398	001109009	Socket head shoulder screw	444	012006118	Top slide leadscrew (mm)	488	012006149	Indexing plate ***
399	012006142	Indexing ring (inch/mm) ***	445	012006119	Top slide leadscrew (inch)	489	012006145	Indexing ring (inch/mm) ***
400	001003104	Cap screw (M5x0,8) ***	446	001008408	Set screw (M10x12)	490	012006146	Handwheel ***
401	012006148	Index plate ***	447	012006041	Washer	491	001017359	Taper pin (4x26) ***
402	012004144	Checking bolt ***	448	001009307	Set screw (M6x10)	492	001001157	Cap screw (M6x20) ***
403	012006143	Handwheel ***	449	012006011	Gib	493	012006128	Flange bearing ***
404	001006160	Tool screw (M10x50) ***	450	012006030	Adjusting screw	494	012006130	Screw *(***)
405	001012111	Nut ***	451	001034026	Snap ring (36)	495	012006151	Screw *(***)
406	001014014	Washer ***	452	001001207	Cap screw (M8x20)	496	001001155	Cap screw (M6x12) ***
407	012006043	Bolt ***	453	001018001	Taper pin (6x24)	497	001017364	Taper pin (4x40) ***
408	012006029	Tool post ***	454	012006120	Nut (mm)	498	012006131	Stop ***
409	012006012	Rear tool post *(***)	455	012006121	Nut (inch)	499	012006127	Support *(***)
410	012006053	Rear tool post *(***)	456	001008308	Set screw (M6x12)	500	012006150	Support *(***)
413	013006033	Bolt *(***)	457	001009309	Set screw (M6x16)	501	001014011	Washer ***
414	013006047	Bolt *(***)	458	012006102	Cross slide *	502	012006129	Flange bearing ***
415	012006058	Cover	459	012006137	Cross slide **	503	012006132	Bushing ***
416	001008305	Set screw (M6x6)	460	013006033	Bolt	504	001133112	Oil ring ***
417	012006117	Cover	461	001014014	Washer	505	001127030	Ball (6,5) ***
418	001012011	Nut	462	012006103	Indexing ring	506	012006133	Piston ***
419	001014016	Washer	463	001012111	Nut	507	012006125	Spacer
420	001305005	Bearing 51102	464	001033016	Snap ring (18)	508	001129012	Handle
421	001001257	Cap screw (M10x40)	465	012006021	Pivot	509	001305009	Bearing 51104
422	001017409	Taper pin (5x26)	466	001109010A	Socket head shoulder screw	510	012006106	Flanged bushing
423	012006135	Bracket *	467	001109005A	Handle			
424	012006138	Bracket **	468	001017407	Taper pin (5x22)			
			469	012006113	Bushing			

* Models MS-1400 S/E and MS-175 S/E
 ** Models MS-1600 S/E and MS-205 AS/AE
 *** Optional

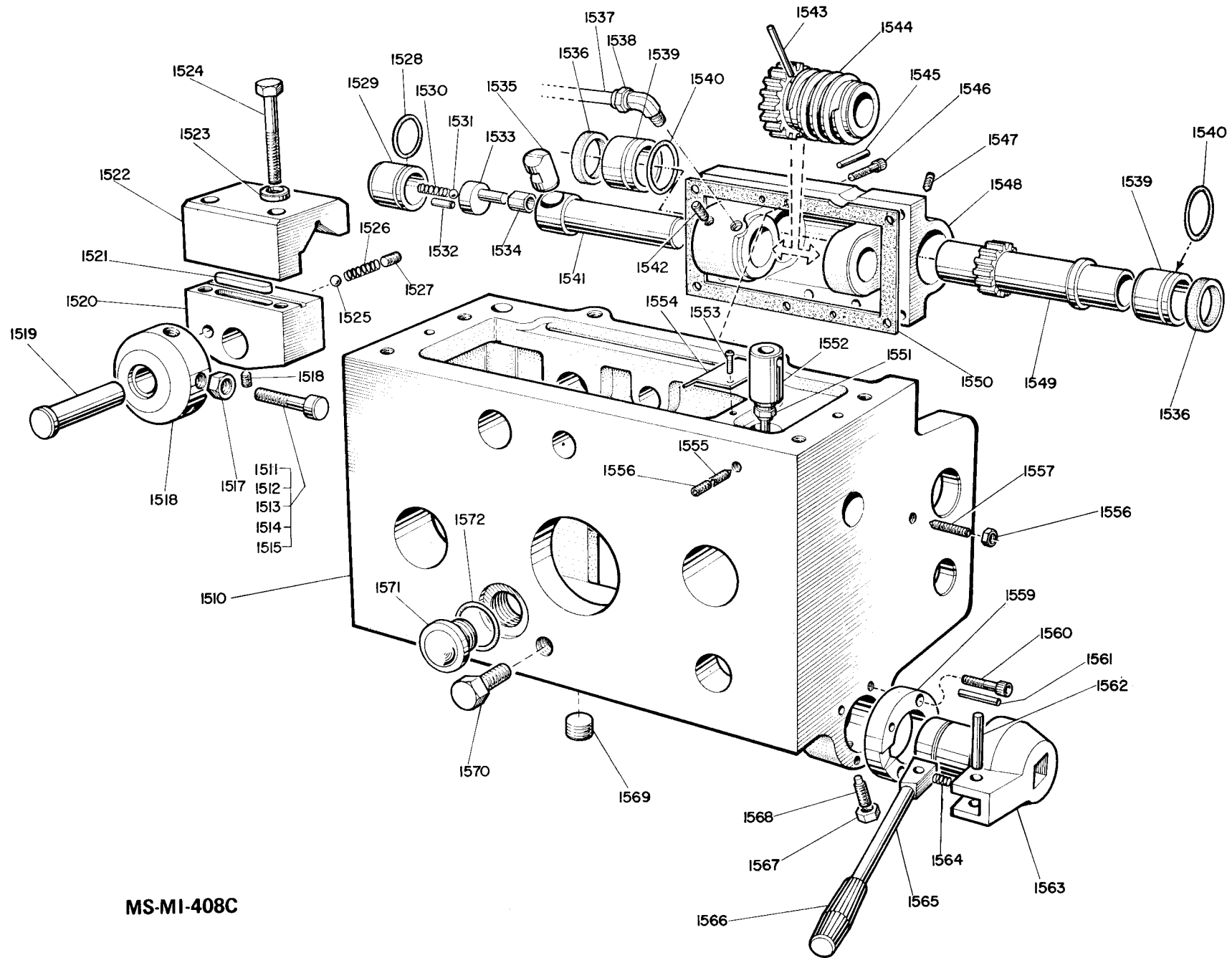

MS-MI-408C

**APRON MS-MI-408C
(left hand)**

REF.	NUMBER	NAME	REF.	NUMBER	NAME	REF.	NUMBER	NAME
1510	012004201	Apron casting	1531	001127030	Ball (6,5)	1552	015004066	Bushing
1511	012004182	Screw (M10x33)	1532	001021255	Split pin (4x12)	1553	001003054	Cap screw (M4x7)
1512	012004183	Screw (M10x43)	1533	012001086	Excentric pin	1554	012004259	Protector
1513	012004184	Screw (M10x48)	1534	012001083	Bushing	1555	001009308	Set screw (M6x12)
1514	012004185	Screw (M10x53)	1535	012001084	Impeller	1556	001008307	Set screw (M6x10)
1515	012004186	Screw (M10x58)	1536	001113201	Oli seal	1557	012004253	Screw
1516	012004230	Handle boss	1537	001231003	Pipe (nylon 1/4")	1558	001012110	Nut
1517	001012002	Nut	1538	001229006	Connector	1559	012004057	Ratchet
1518	001009408	Set screw (M10x12)	1539	012004032	Bushing	1560	001001107	Cap screw (M5x12)
1519	012004177	Shaft	1540	001133121	Oil ring	1561	001021309	Split pin (5x20)
1520	012004214	Bracket	1541	012004235	Shaft	1562	001020462	Pin (6x32)
1521	001023162	Key	1542	001009307	Set screw (M6x10)	1563	012004056	Handle boss
1522	012004213	Bracket	1543	001017412	Taper pin (5x32)	1564	001117090	Spring
1523	001014014	Washer	1544	012004229	Worm	1565	012004228	Lever
1524	001005210	Hexagonal head screw (M10x60)	1545	001017406	Taper pin (5x20)	1566	001108030	Handle
1525	001127040	Ball (8)	1546	001001206	Cap screw (M8x16)	1567	001012001	Nut
1526	001117115	Spring	1547	001009307	Set screw (M6x10)	1568	001010359	Set screw (M8x20)
1527	001008408	Set screw (M10x12)	1548	012004210	Bracket	1569	001205004	Plug
1528	001133119	Oil ring	1549	012004029	Gear	1570	015004054	Stop
1529	012004236	Pump housing	1550		Gasket	1571	001118010	Oil sight
1530	001117052	Spring	1551	001227007	Connector	1572	001133117	Oil ring

MS-MI-409C

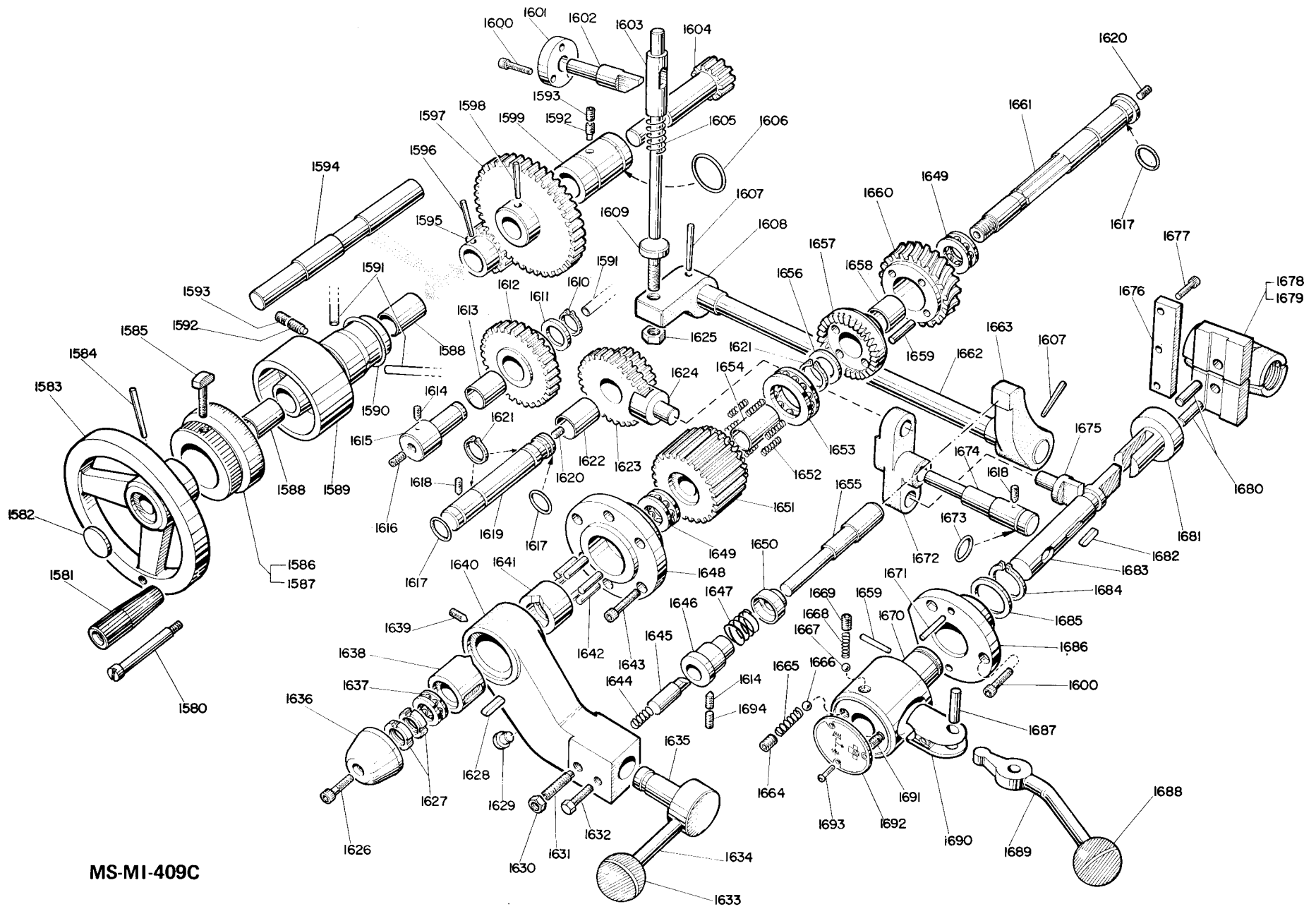

APRON MS-MI-409C
(left hand)

REF.	NUMBER	NAME	REF.	NUMBER	NAME	REF.	NUMBER	NAME
1580	001109010A	Shaft	1619	012004245	Shaft	1658	001114256	Bushing
1581	001109005A	Handle	1620	001008556	Set screw (M5x8)	1659	001020460	Pin (6x24)
1582	001130105	Cover	1621	001033018	Snap ring (20)	1660	012004209	Worm gear
1583	001100040B	Handwheel	1622	001114258	Bushing	1661	012004224	Shaft
1584	001017416	Taper pin (5x50)	1623	012004221	Gear	1662	012004231	Shaft
1585	013006023A	Screw	1624	012004247	Shifting fork	1663	012004206	Lever
1586	012004216	Indexing ring (mm)	1625	001012002	Nut	1664	001008409	Set screw (M10x20)
1587	012004217	Indexing ring (inch)	1626	001001106	Cap screw (M5x16)	1665	001117120	Spring
1588	001114208	Bushing	1627	001030003	Nut	1666	001127040	Ball (8)
1589	012004203	Flange	1628	001023105	Key	1667	001127030	Ball (6,5)
1590	001133128	Oil ring	1629	015004068	Protector	1668	001117045	Spring
1591	001263102	Pipe	1630	001012109	Nut	1669	001008357	Set screw (M8x10)
1592	001010409	Set screw (M10x20)	1631	001010309	Set screw (M6x20)	1670	012004215	Handle shifting register
1593	001008408	Set screw (M10x12)	1632	001008311	Set screw (M6x25)	1671	001017406	Taper pin (5x20)
1594	012004244	Shaft	1633	001105030	Ball	1672	012004205	Shifting fork
1595	012004243	Gear	1634	012004249	Lever	1673	001133112	Oil ring
1596	001017412	Taper pin (5x32)	1635	012004232	Pin	1674	012004239	Shaft
1597	012004219	Gear	1636	012004207	Cover	1675	012004246	Shifting fork
1598	001017414	Taper pin (5x40)	1637	001305007	Bearing 51103	1676	012004252	Gib
1599	012004208	Bushing	1638	012004240	Cam	1677	001001105	Cap screw (M5x12)
1600	001001155	Cap screw (M6x12)	1639	001009307	Set screw (M6x10)	1678	012004260	Double half nut (mm)
1601	012004233	Cover	1640	012004202	Bracket	1679	012004212	Double half nut (inch)
1602	012004234	Pin	1641	012004241	Cam	1680	001020558	Pin (10x18)
1603	012004238	Pin	1642	013004121	Pin	1681	012004225	Cam
1604	012004242	Rack pinion	1643	001001156	Cap screw (M6x16)	1682	001023106	Key
1605	001117275	Spring	1644	001117270	Spring	1683	012004226	Shaft
1606	001133122	Oil ring	1645	013004124	Pin	1684	001033027	Snap ring (32)
1607	001017413	Taper pin (5x36)	1646	013004123	Bearing	1685	012004254	Spacer
1608	012004211	Lever	1647	001117410	Spring	1686	012004218	Cover
1609	015004016	Screw	1648	012004204	Cover	1687	001020561	Pin (10x28)
1610	001033016	Snap ring (18)	1649	001305009	Bearing 51104	1688	001105020	Ball
1611	012004048	Spacer	1650	012004258	Spring housing	1689	012004237	Lever
1612	012004220	Double gear	1651	012004222	Gear	1690	012004227	Wedge
1613	001114207	Bushing	1652	001117085	Spring	1691	001010306	Set screw
1614	001009308	Set screw (M6x12)	1653	001305019	Bearing 51107X	1692	012004255	Plate
1615	012004250	Shaft	1654	001114259	Bushing	1693	001036154	Cap screw (M3x8)
1616	001008358	Set screw (M8x12)	1655	012004248	Shaft	1694	001008308	Set screw (M6x12)
1617	001133113	Oil ring	1656	012004251	Spacer			
1618	001009310	Set screw (M6x20)	1657	012004223	Clutch			

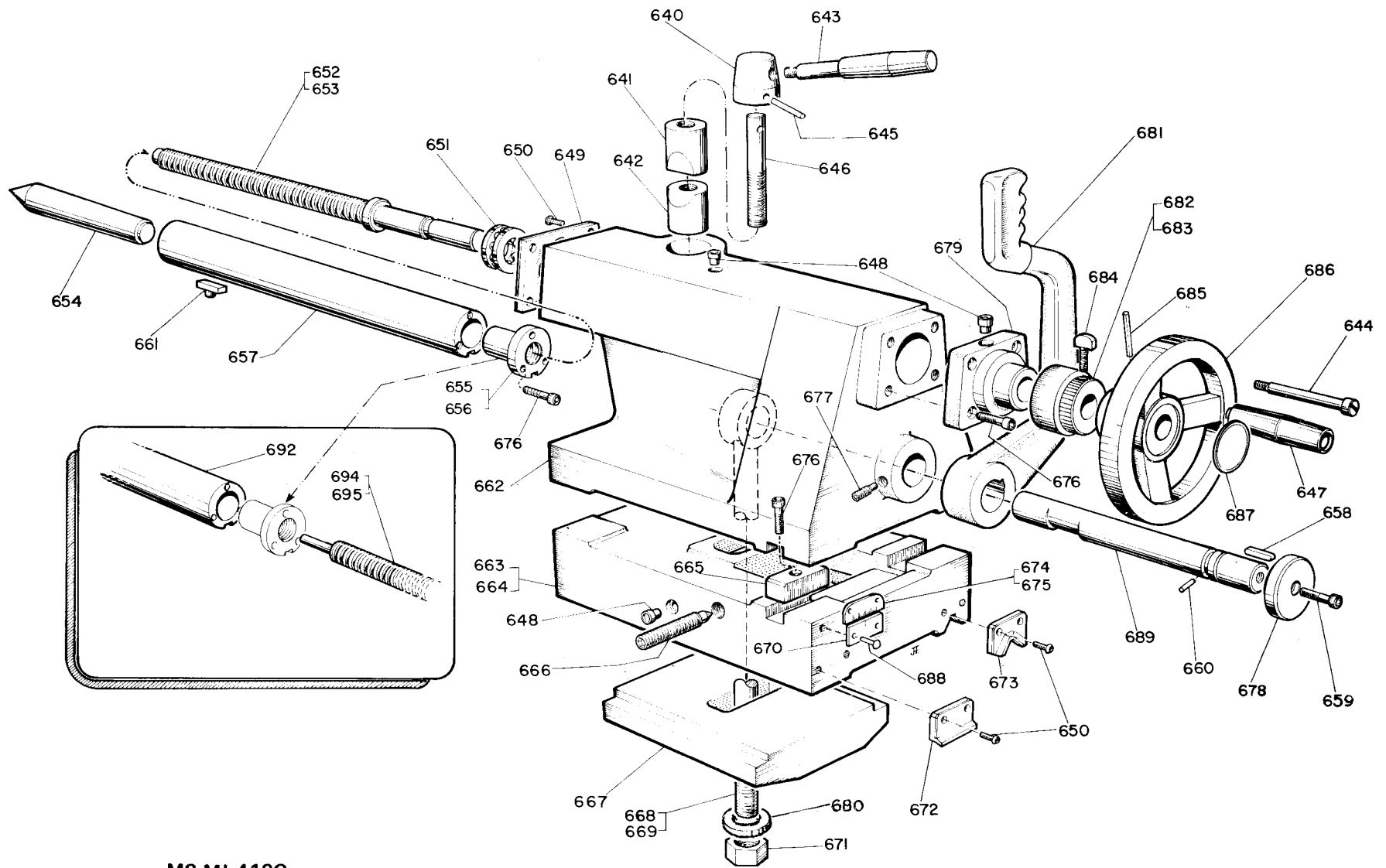

MS-MI-410C

TAILSTOCK MS-MI-410C

REF.	NUMBER	NAME	REF.	NUMBER	NAME	REF.	NUMBER	NAME
640	013003015	Handle boss	660	001020409	Pin (5x20)	680	012003070	Washer
641	012003062	Motion bushing	661	013003020	Key	681	012003033	Lever
642	013003018	Fix bushing	662	012003051	Tailstock casting	682	012003058	Indexing ring (mm)
643	001112040	Lever	663	012003052	Base *	683	012003059	Indexing ring (inch)
644	001109010A	Socket head shoulder screw	664	012003063	Base **	684	013003025A	Screw
645	001017364	Taper pin (4x40)	665	012003030	Key	685	001017416	Taper pin (5x50)
646	013003016	Stud	666	001009467	Set screw (M12x60)	686	001100030B	Handwheel
647	001109005A	Handle	667	012003004	Clamp	687	001130105	Cover
648	001122001	Oiler	668	012003068	Bolt *	688	001035010	Rivet
649	013003028	Cover	669	012003069	Bolt **	689	012003014	Shaft
650	001003105	Cap screw (M5x12)	670	013003007	Indexing plate			
651	001305009	Bearing 51104	671	001012113	Nut			CATCH DRILL QUILL
652	012003060	Tailstock screw (mm)	672	013003027	Wiper			(optional)
653	012003061	Tailstock screw (inch)	673	013003029	Wiper	692	012003053	Barrel
654	001121004	Center MT-3	674	012003011	Indexing plate (mm)	694	012003064	Tailstock screw (mm)
655	012003055	Nut (mm)	675	012003023	Indexing plate (inch)	695	012003065	Tailstock screw (inch)
656	012003056	Nut (inch)	676	001001157	Cap screw (M6x20)			
657	012003054	Barrel	677	001010358	Set screw (M8x16)	*		Models MS-175 S/E and MS-1400 S/E
658	001023106	Key	678	012003018	Cover	**		Models MS-205 AS/AE and MS-1600 S/E
659	001001107	Cap screw (M5x20)	679	012003057	Tailstock screw guide			

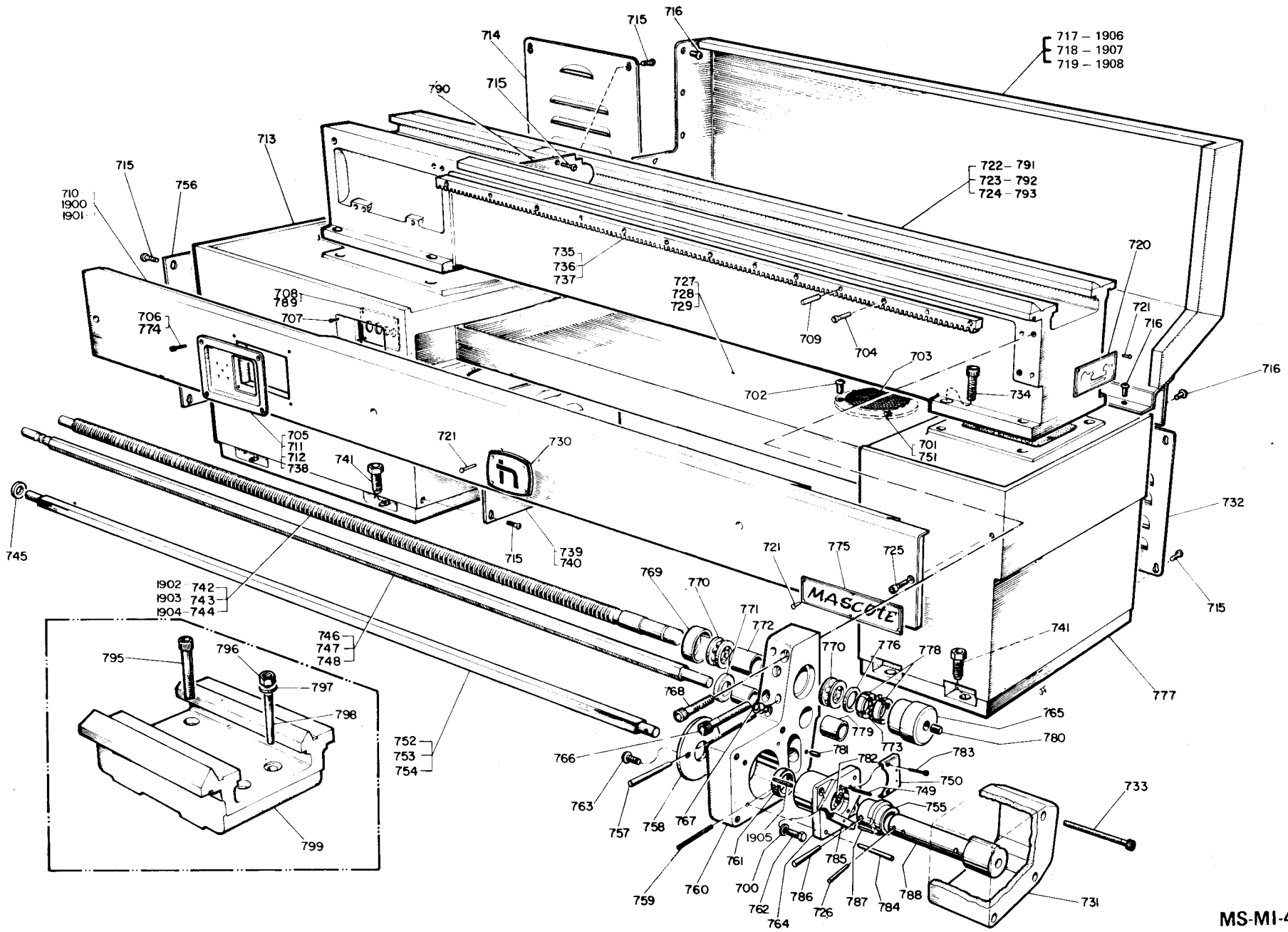

MS-MI-411C

BED MS-MI-411C

REF.	NUMBER	NAME	REF.	NUMBER	NAME	REF.	NUMBER	NAME
700	001014011	Washer	739	012002024	Cover	777	012002011	Plinth (tail end)
701	013002041	Flange ***	740	012002061	Brake motor cover	778	001030005	Nut
702	001003104	Cap screw (M5x10)	741	012002046	Jacking bolt	779	001114105	Bushing
703	013002042	Screen ***	742	012002097	Leadscrew (4 T.P.I.)(500)(20'')	780	001008305	Set screw (M6x6)
704	001001107	Cap screw (M5x20)	743	012002098	Leadscrew (4.T.P.I.)(800)(32'')	781	001009307	Set screw (M6x10)
705	012002081	Cover (9 speeds) ****	744	012002099	Leadscrew (4 T.P.I.)(1000)(40'')	782	001116030	Spring
706	001003156	Cap screw (M6x16)(9speeds)*****	745	012002059	Collar	783	001001106	Cap screw (M5x16)
707	001001057	Cap screw (M4x16) ***	746	012002028	Feed shaft (500)(20'')	784	001017407	Taper pin (5x22)
708	012002084	Support (9 speeds) ***	747	012002029	Feed shaft (800)(32'')	785	013002037	Ratchet guide
709	001017407	Taper pin (5x22)	748	012002030	Feed shaft (1000)(40'')	786	001017360	Taper pin (4x28)
710	012002070	Plate *(500)(20'')	749	001021264	Split pin (4x30)	787	001020311	Pin (3x28)
711	012002082	Cover (9 speeds) ***	750	013002065	Support	788	012002066	Shaft
712	012002083	Cover (18 speeds) ***	751	013002062	Flange ****	789	012002085	Support (18 speeds) ***
713	012002010	Plinth (head end)	752	012002040	Third rod shaft (500)(20'')	790	012002057	Cover
714	012002096	Cover	753	012002041	Third rod shaft (800)(32'')	1900	012002102	Plate (800)(32'')
715	001003154	Cap screw (M6x10)	754	012002042	Third rod shaft (1000)(40'')	1901	012002103	Plate (1000)(40'')
716	001003155	Cap screw (M6x12)	755	013002032	Ratchet	1902	012002093	Leadscrew (6mm)(500)(20'')
717	012026001	Splash guard (500)(20'') *	756	012002095	Cover	1903	012002090	Leadscrew (6mm)(800)(32'')
718	012026017	Splash guard (800) (32'') *	757	001017465	Taper pin (6x45)	1904	012002091	Leadscrew (6mm)(1000)(40'')
719	012026018	Splash guard (1000)(40'') *	758	012002067	Cover	1905	001021256	Split pin (4x14)
720	001130001	Data plate	759	001021266	Split pin (4x36)	1906	012026009	Splash guard (500)(20'') **
721	001035010	Rivet	760	012002063	Bracket	1907	012026019	Splash guard (800)(32'') **
722	012002001	Bed (500)(20'')	761	012002068	Collar	1908	012026020	Splash guard (1000)(40'') **
723	012002002	Bed (800)(32'')	762	001004307	Hexagonal head screw (M6x18)			
724	012002003	Bed (1000)(40'')	763	001003155	Cap screw (M6x12)			BED WITH GAP
725	001001158	Cap screw (M6x25)	764	012002065	Flanged bearing	791	012002005	Bed (500)(20'')
726	001017307	Taper pin (3x22)	765	012002047	Cover	792	012002006	Bed (800)(32'')
727	012002077	Tray (500)(20'')	766	001001265	Cap screw (M10x70)	793	012002007	Bed (1000)(40'')
728	012002078	Tray (800)(32'')	767	001122001	Oiler	795	001001261	Cap screw (M10x40)
729	012002079	Tray (1000)(40'')	768	001001263	Cap screw (M10x50)	796	001012001	Nut
730	001130010	Plate	769	012002094	Cover	797	001014013	Washer
731	012002064	Cover	770	001305009	Bearing 51104	798	001019106	Taper pin(8x65)
732	012002025	Cover	771	012002058	Collar	799	012002009	Gap
733	001001164	Cap screw (M6x60)	772	001114255	Bushing	*		MS-175 S/E and MS-1400 S/E
734	001001311	Cap screw (M12x40)	773	001031005	Lock washer	**		MS-205 AS/AE and MS-1600 S/E
735	012002032	Rack (500)(20'')	774	001001156	Cap screw (M6x16)	***		Lathes with coolant unit.
736	012002033	Rack (800)(32'')			(9/18 speeds)*** (18 speeds)*****	****		Lathes without coolant unit.
737	012002034	Rack (1000)(40'')	775	012002060	Name plate			
738	012002089	Cover (18 speeds)*****	776	012002062	Washer			

BED WITH GAP

791	012002005	Bed (500)(20'')
792	012002006	Bed (800)(32'')
793	012002007	Bed (1000)(40'')
795	001001261	Cap screw (M10x40)
796	001012001	Nut
797	001014013	Washer
798	001019106	Taper pin(8x65)
799	012002009	Gap
*		MS-175 S/E and MS-1400 S/E
**		MS-205 AS/AE and MS-1600 S/E
***		Lathes with coolant unit.
****		Lathes without coolant unit.

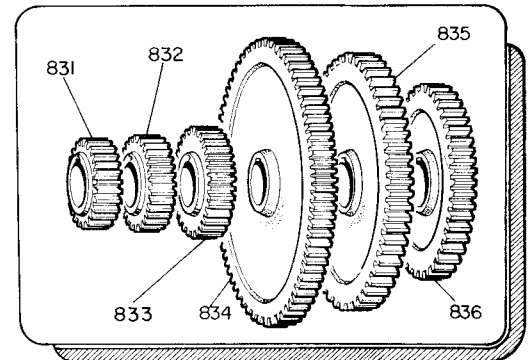
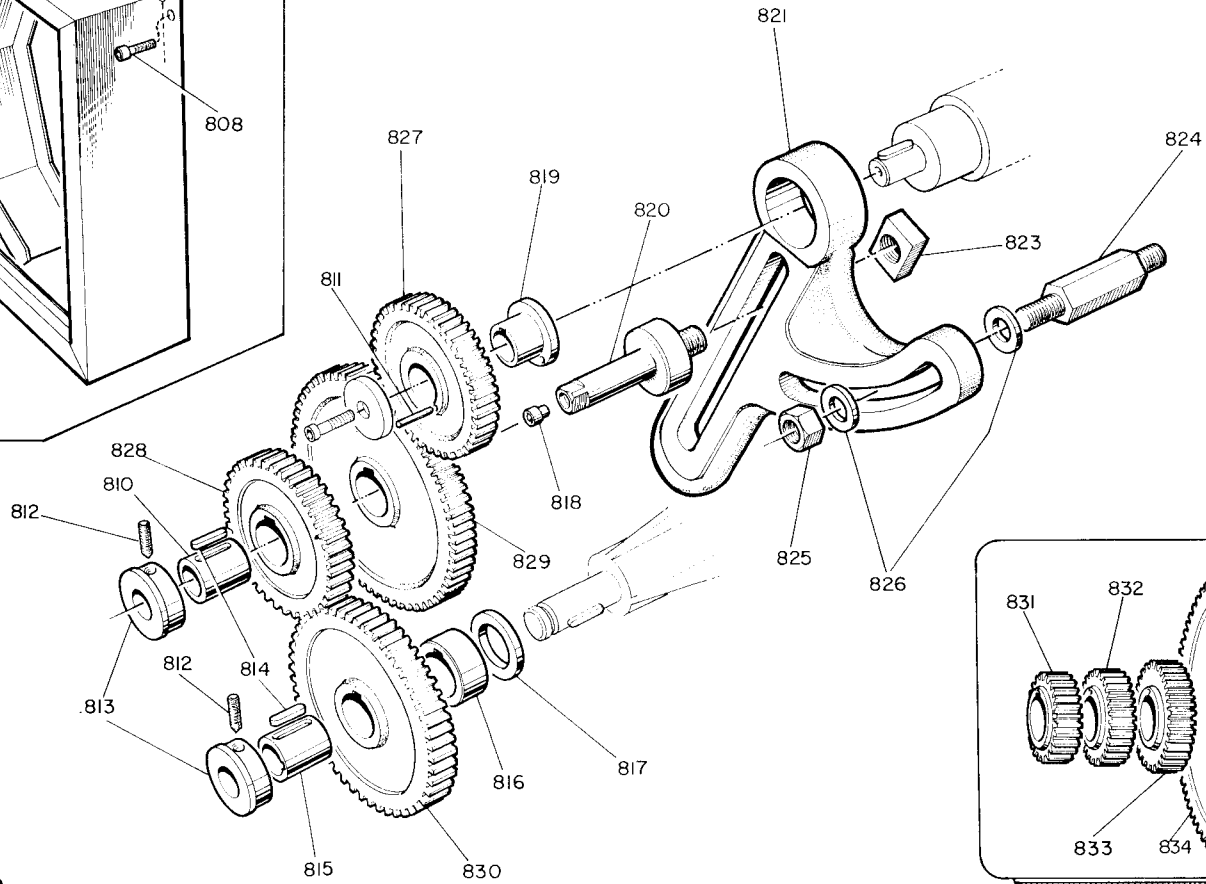
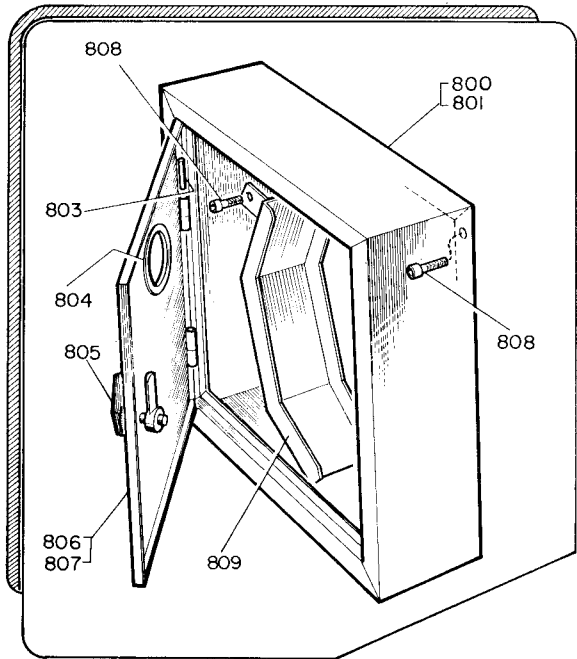

MS-MI-412C

**CHANGE GEARS MS-MI-412C
(leadscrew pitch - 4 TPI)**

REF.	NUMBER	NAME	REF.	NUMBER	NAME	REF.	NUMBER	NAME
800	012014030	End cover*	813	012014017	Washer	826	001014015	Washer
801	012014031	End cover**	814	001023110	Key	827	012014027	Gear Z=71
803	013014039	Pin	815	012014021	Bushing	828	012014042	Gear Z=75
804	014014041	Ring	816	012014023	Spacer	829	012014026	Gear Z=113
805	001518017	Door lock	817	012014022	Collar	830	012014039	Gear Z=120
806	012014013	Door*	818	001122001	Oiler	831	012014028	Gear Z=40
807	012014014	Door**	819	012014019	Bushing	832	012014003	Gear Z=47
808	001001155	Cap screw (M6x12)	820	012014004	Shaft	833	012014041	Gear Z=50
809	012014032	Splash guard	821	012014001	Swing bracket	834	012014024	Gear Z=127
810	012014018	Bushing	823	012014005	Nut	835	012014025	Gear Z=100
811	012014020	Safety pin	824	013014013	Pin	836	012014044	Gear Z=76
812	001009308	Set screw (M6x12)	825	001012112	Nut			

* MS-MI-1400S/E and MS-MI-175E

** MS-1600S/E and MS-205AS/AE

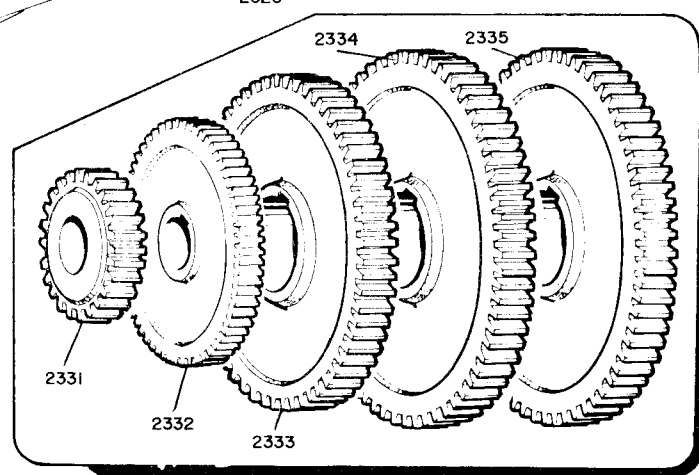
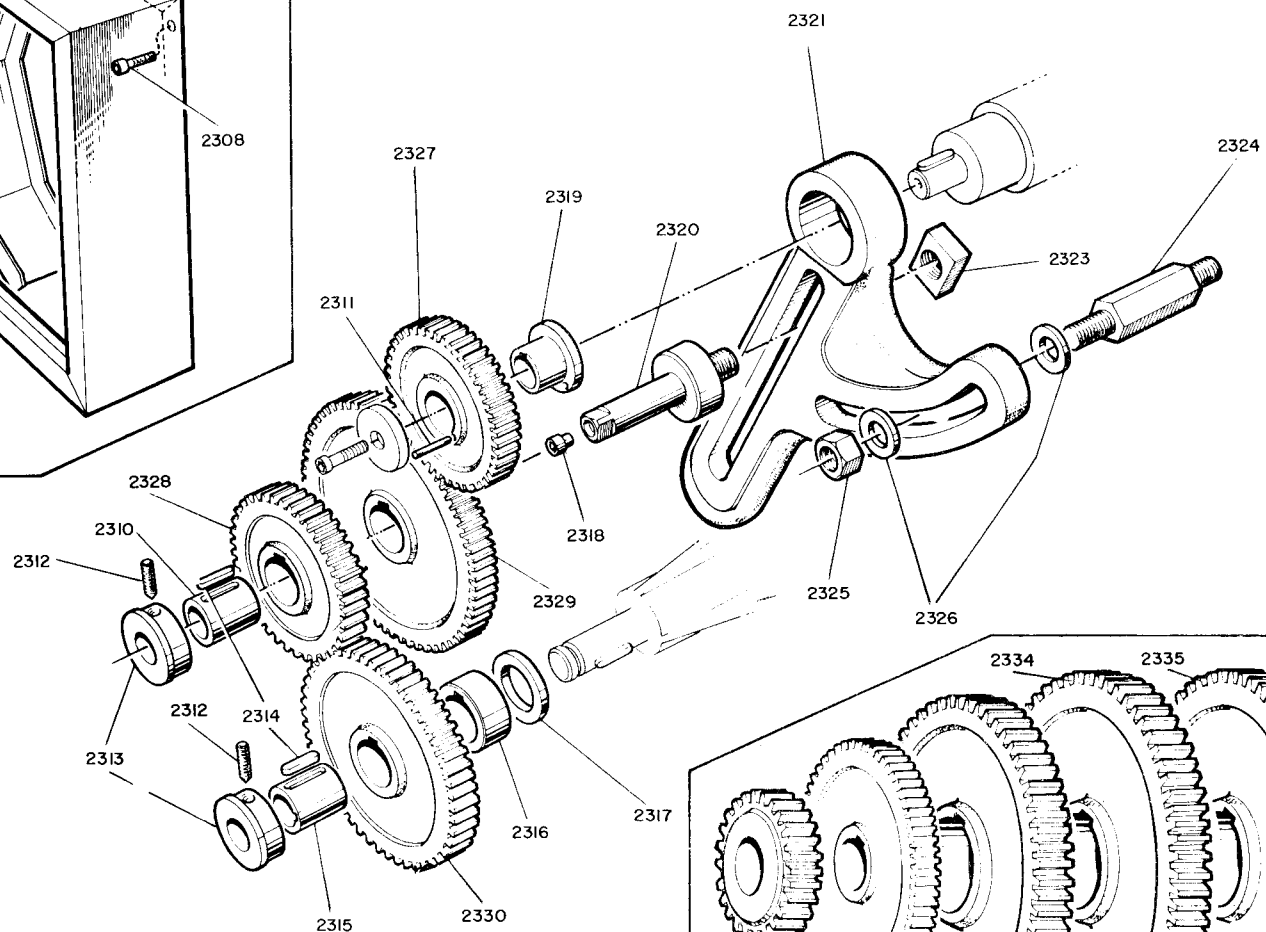
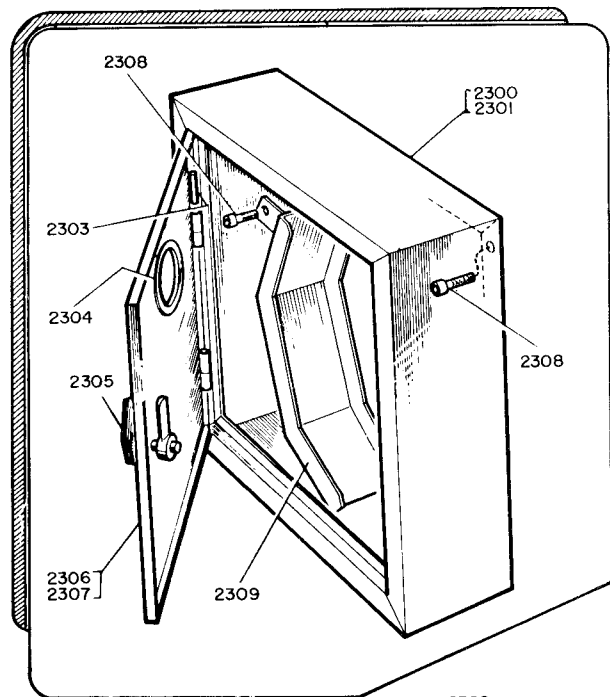

MS-MI-413C

CHANGE GEARS MS-MI-413C
(leadscrew pitch - 6mm)

REF. NUMBER	NAME	REF. NUMBER	NAME	REF. NUMBER	NAME			
2300	012014030	End cover*	2313	012014017	Washer	2326	001014015	Washer
2301	012014031	End cover**	2314	001023110	Key	2327	012014027	Gear Z=71
2303	013014039	Pin	2315	012014021	Bushing	2328	012014038	Gear Z=72
2304	014014041	Ring	2316	012014023	Sleeve	2329	012014040	Gear Z=123
2305	001130200	Door lock	2317	012014022	Spacer	2330	012014025	Gear Z=100
2306	012014013	Door*	2318	001122001	Oiler	2331	012014028	Gear Z=40
2307	012014014	Door**	2319	012014019	Bushing	2332	012014029	Gear Z=80
2308	001001155	Cap screw (M6x12)	2320	012014004	Shaft	2333	012014026	Gear Z=113
2309	012014032	Splash guard	2321	012014001	Swing bracket	2334	012014039	Gear Z=120
2310	012014018	Bushing	2323	012014005	Nut	2335	012014024	Gear Z=127
2311	012014020	Safety pin	2324	012014037	Pin			* Models MS-1400S/E and MS-175S/E
2312	001009308	Set screw (M6x12)	2325	001012112	Nut			** Models MS-1600S/E and MS-205AS/AE

57

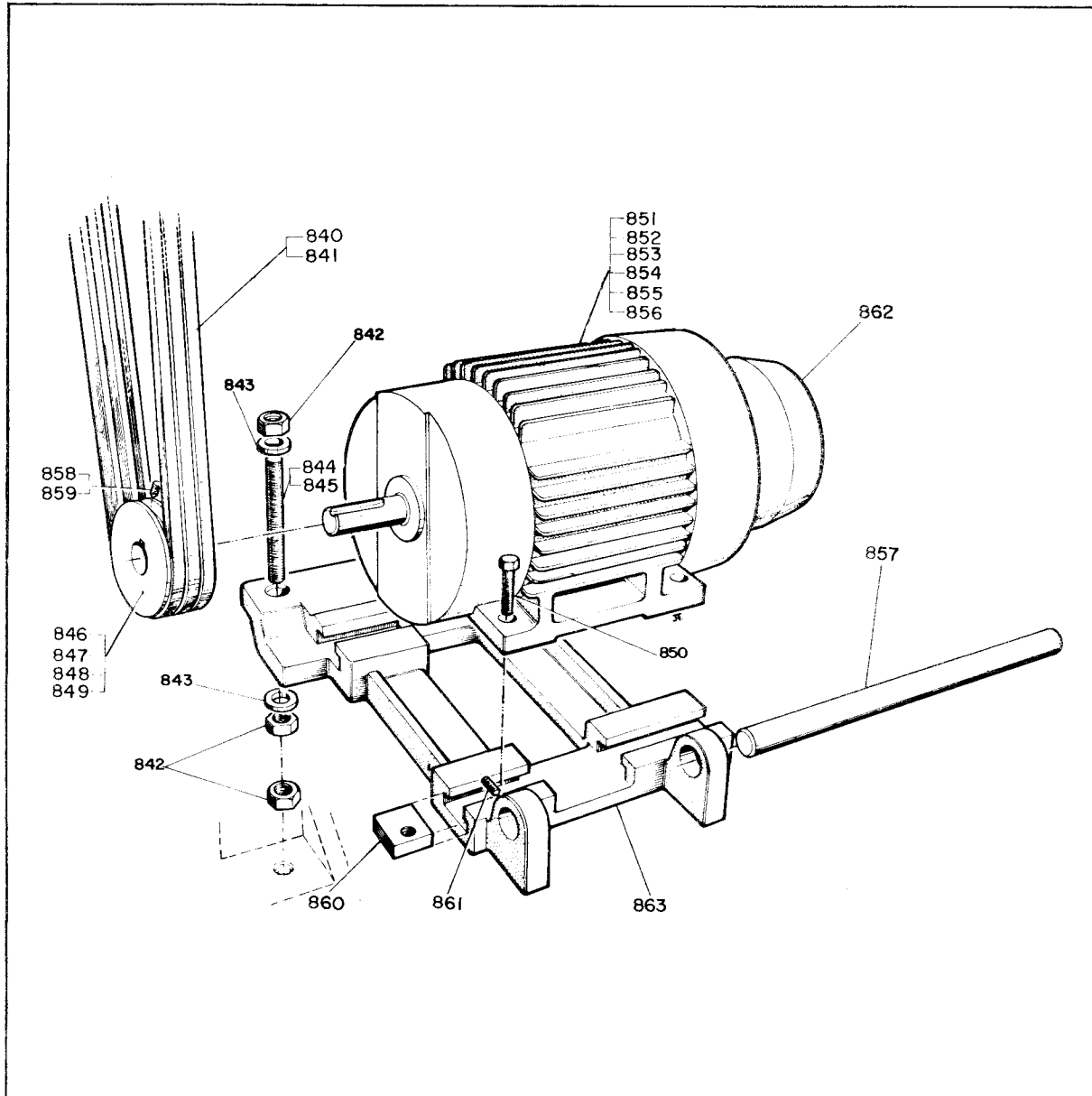

MOTOR DRIVE SYSTEM MS-MI-414C

REF.	NUMBER	NAME
840	A - 68	Belts (*) (**)
841	A - 69	Belts (***) (****)
842	001012112	Nut
843	012007009	Washer
844	012007011	Stud (main motor without brake)
845	012007010	Stud (main motor with brake)
846	012007023	Pulley - 60Hz (*) (***)
847	012007026	Pulley - 50Hz (*) (***)
848	013007024	Pulley - 60Hz (**)(****)
849	012007005	Pulley - 50Hz (**)(****)
850	001004412	Hexagonal head screw (M10x40)
851	00113630103	Main motor (60cv-60Hz)(*)(***)
852	00113630106	Main motor (5,5cv-50Hz)(*)(***)
853	00113635102	Main motor (6,3/4cv-50/60Hz)(**)(****)
854	00113630203	Main motor (with brake) (6cv-60Hz)(*)(***)
855	00113630205	Main motor (with brake) (5,5cv-50Hz)(*)(***)
856	00113635202	Main motor (with brake) (6,3/4cv-50/60Hz)(**)(****)
857	012007013	Shaft
858	001011309	Set screw (M6x16)
859	001011306	Set screw (M6x8)
860	012007008	Nut
861	001008308	Set screw (M6x12)
862	012007012	Brake
863	012007007	Base

(*) MS-175S and MS-1400S

(**) MS-175E and MS-1400E

(***) MS-205 AS and MS-1600S

(****) MS-205AE and MS-1600E

STEADY REST

MS-MI-415C

REF. NUMBER NAME

865	001017307	Taper pin (3x22)
866	001126010	Hand knob
867	010009003	Collar
868	012009007	Screw
869	012009005	Governor sleeve
870	010009007	Bronze point
871	012010010	Casting (MS-1400 S/E and MS-175 S/E)
872	012010011	Casting (MS-1600 S/E and MS-205 AS/AE)
873	012010009	Clamping plate
874	001021268	Split pin (4x45)
875	012010008	Screw
876	001012112	Nut
877	001014015	Washer
878	001005261	Hexagonal head screw (M12x80)

ASSEMBLY WITH BEARINGS

(optional)

879	012009006	Governor sleeve
880	001009255	Set screw (M4x6)
881	010009010	Spacer
882	001034015	Snap ring (22)
883	001304005	Bearing 608 - 2RS
884	010009009	Roller
885	010009008	Shaft

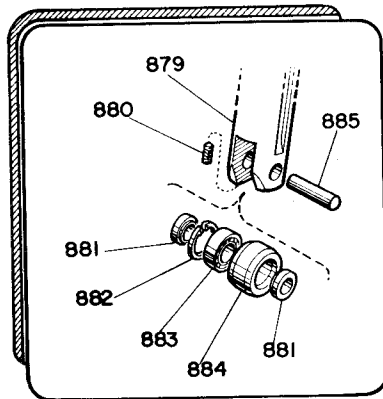
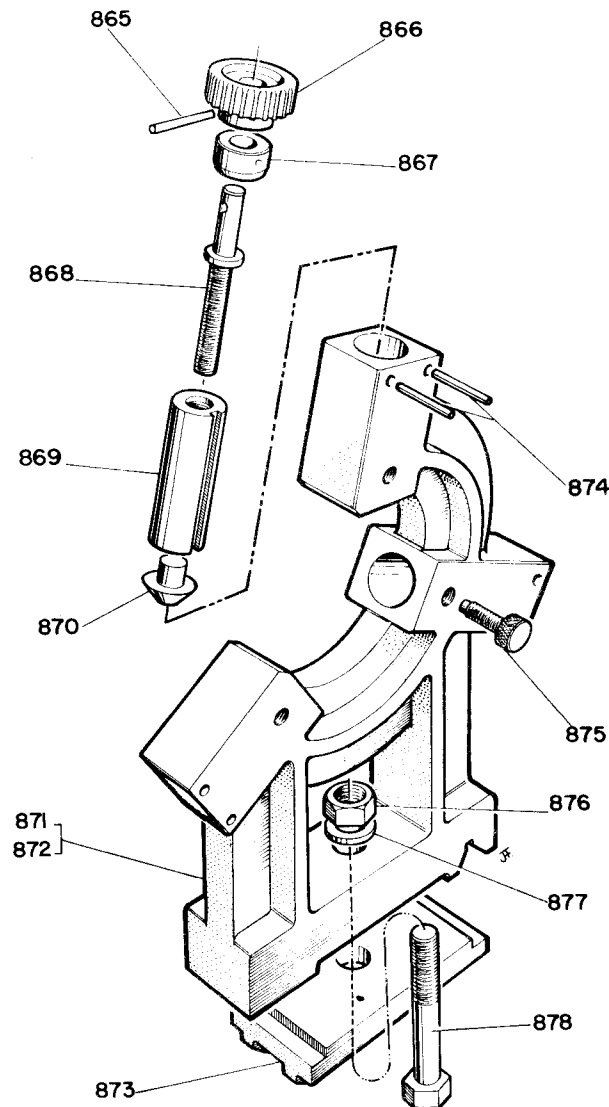

FOLLOW REST

MS-MI-416C

REF. NUMBER NAME

890	001126010	Hand knob
891	001017307	Triaper pin (3x22)
892	012009005	Governor sleeve
893	010009007	Bronze point
894	010009003	Collar
895	012009007	Screw
896	001005208	Hexagonal head screw (M10x4)
897	001014014	Washer
898	012009003	Casting (MS-1400S/E and MS-175 S/E)
899	012009004	Casting (MS-1600 S/E and MS-205 AS/AE)
900	012010008	Screw
901	001021268	Split pin (4x45)

ASSEMBLY WITH BEARINGS

(optional)

902	012009006	Governor sleeve
903	001009255	Set screw (M4x6)
904	010009010	Spacer
905	001034015	Snap ring (22)
906	001304005	Bearing 608 - 2RS
907	010009009	Roller
908	010009008	Shaft

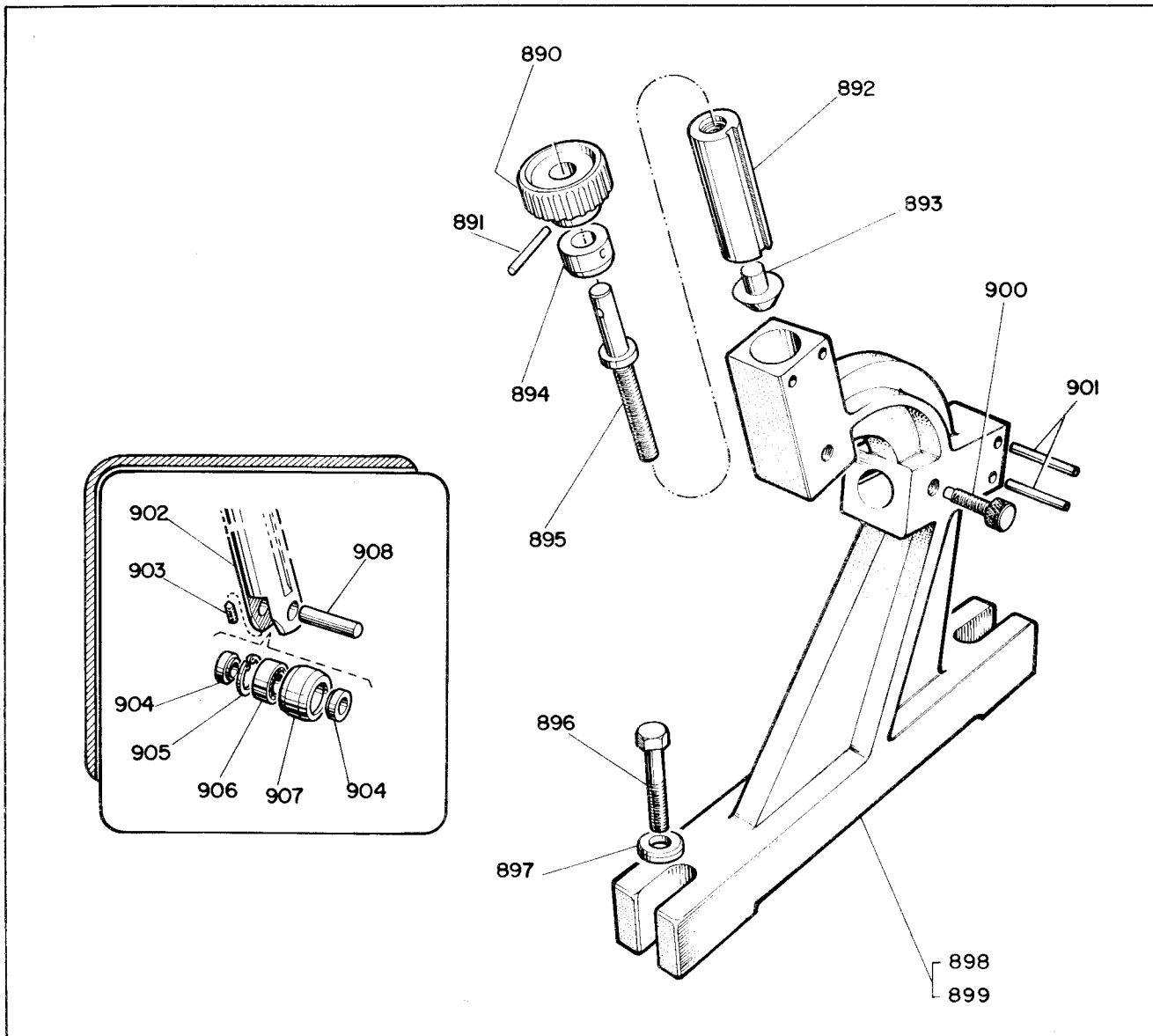

TOOL POST - 4 WAY TURRET

MS-MI-417C

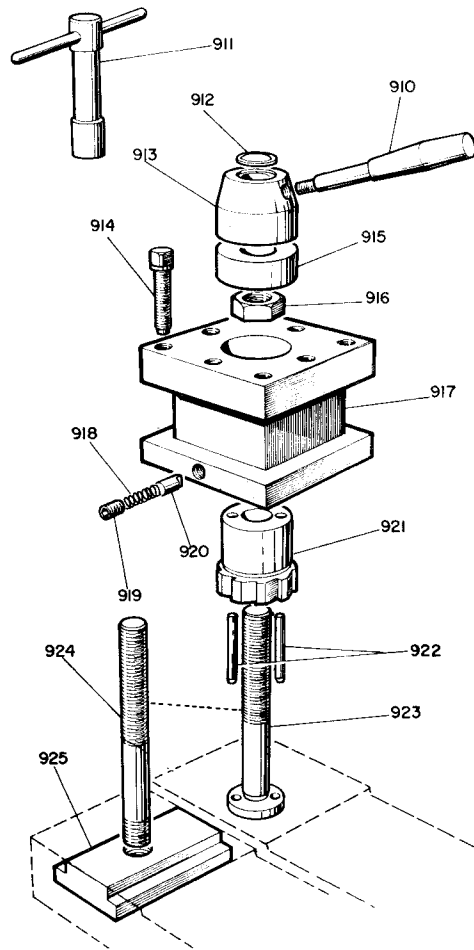

REF.	NUMBER	NAME
910	012019006	Lever
911	012019008	Wrench
912	001130150	Cover
913	012019004	Turret cap head
914	001006160	Tool screw (M10x50)
915	012019005	Collar
916	001012113	Nut
917	012019001	Turret
918	013019008	Spring
919	001008356	Set screw (M8x8)
920	012019007	Lock pin
921	012019002	Ratchet
922	001020414	Pin (5x40)
923	012019011	Shaft
924	012019012	Shaft "T"
925	012019013	Key "T"

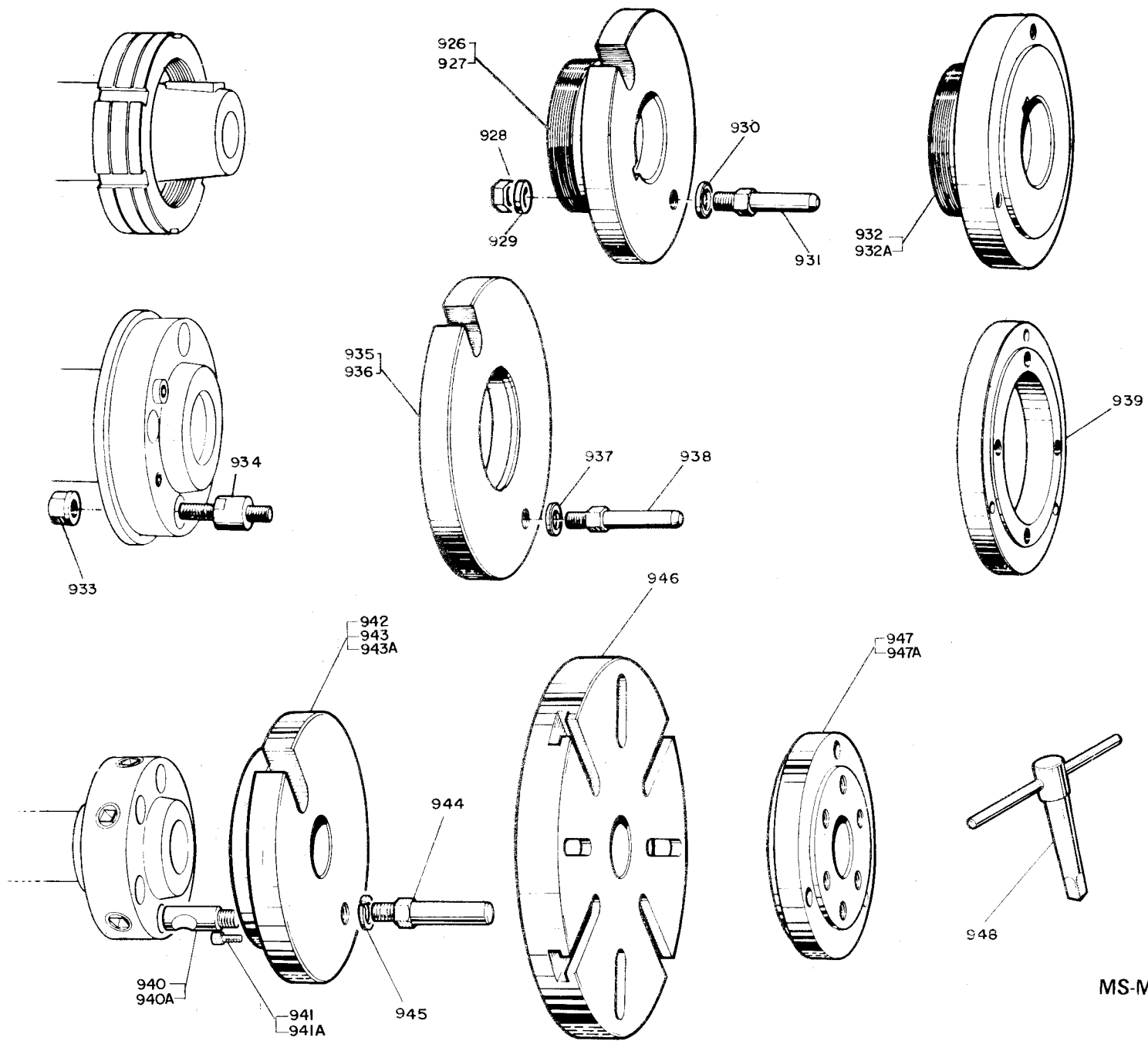

MS-MI-418C

MS-MI-418C

SPINDLE NOSE ASA LO

SPINDLE NOSE DIN 55022 - 5

SPINDLE NOSE CAM-LOCK

DRIVE PLATE

REF.	NUMBER	NAME
926	013023001	Plate*
927	013023003	Plate**
928	001012003	Nut
929	001015008	Washer
930	001014015	Washer
931	012023002	Drag pin

DRIVE PLATE

REF.	NUMBER	NAME
933	001107131	Nut
934	001107123	Stud
935	012023001	Plate*
936	012023002	Plate**
937	001015008	Washer
938	012023006	Drag pin

DRIVE PLATE

REF.	NUMBER	NAME
940	001107044	Pin (D1 - 5)
940A	001107045	Pin (D1 - 6)
941	001028254	Cap screw
941A	001028305	Cap screw
942	013023004	Plate (D1 - 5)*
943	013023005	Plate (D1 - 5)**
943A	012023003	Plate (D1 - 6)
944	013023006	Drag pin
945	001015008	Washer

UNIVERSAL CHUCK FLANGE

932	012024001	Flange (chuck standard")
932A	012024002	Flange (chuck super)

UNIVERSAL CHUCK FLANGE

933	001107131	Nut
934	001107123	Stud
939	012024005	Flange

BACK PLATE

940	001107044	Pin (D1 - 5)
941	001028254	Cap screw (D1 - 5)
946	012049001	Plate (D1 - 5)

UNIVERSAL CHUCK FLANGE

940	001107044	Pin (D1 - 5)
940A	001107045	Pin (D1 - 6)
941	001028254	Cap screw (D1 - 6)
941A	001028305	Cap screw (D1 - 5)
947	012024003	Plate (D1 - 6)
947A	012024004	Plate (D1 - 6)

948	001107055	Wrench
-----	-----------	--------

* Models MS-1400 S/E and MS-175 S/E

** Models MS-1600 S/E and MS-205 AS/AE

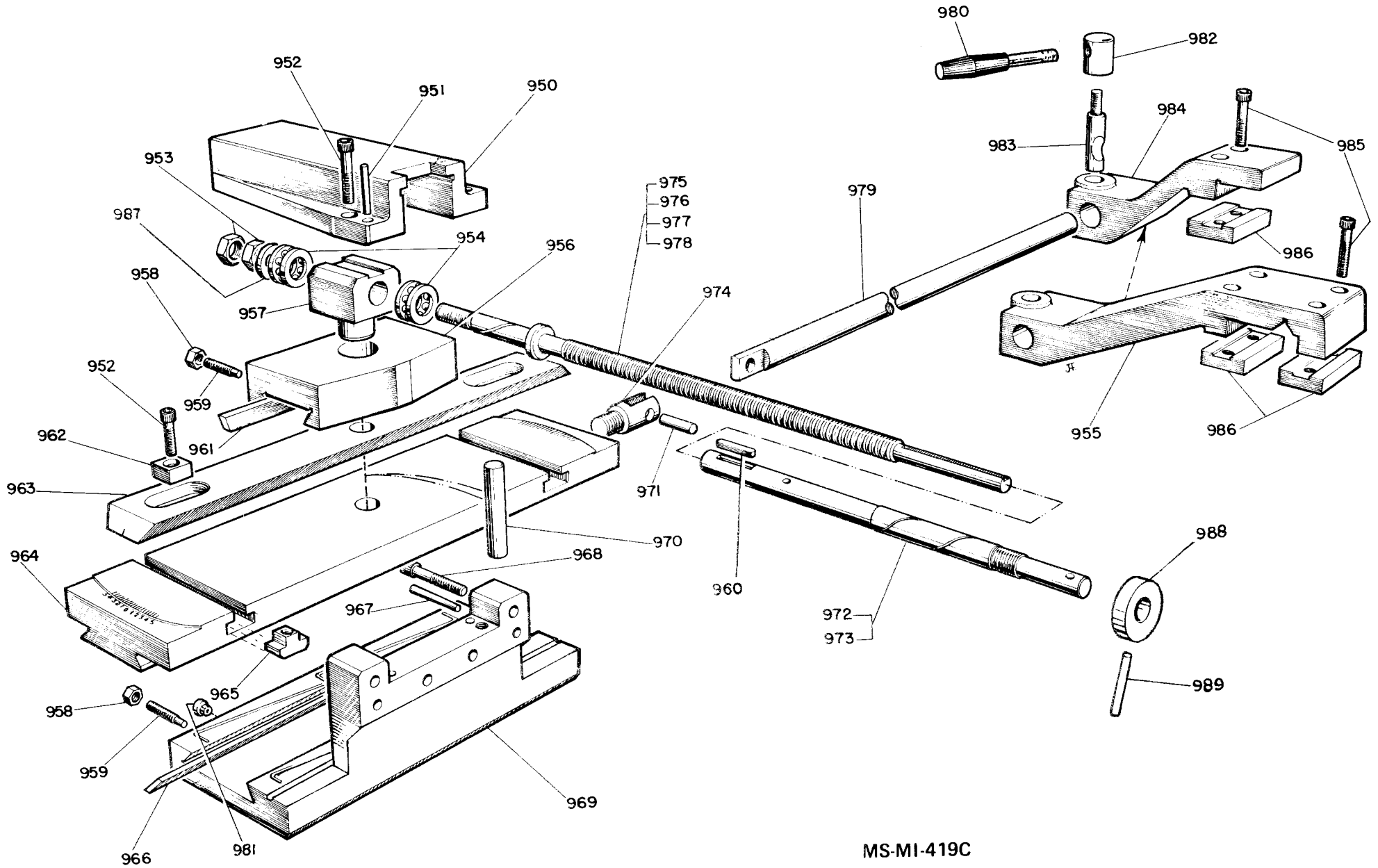

MS-MI-419C

TAPER ATTACHMENT MS-MI-419C

(optional)

REF. NUMBER	NAME	REF. NUMBER	NAME	REF. NUMBER	NAME
950	012017058 Plate	964	012017001 Plate	978	012017064 Screw (inch) **
951	001018003 Pin (6x28)	965	001022004 Nut	979	012017016 Rod
952	001001207 Cap screw (M8x20)	966	012017023 Gib	980	0120112030 Handle
953	001030003 Nut	967	001018057 Pin (8x40)	981	001122001 Oiler
954	001305005 Bearing 51102	968	001001260 Cap screw (M10x35)	982	012017017 Handle boss
955	012017060 Bracket **	969	012017057 Base plate	983	012017021 Stem
956	012017013 Slide block	970	012017024 Pivot	984	012017059 Bracket *
957	012017015 Yoke	971	001020511 Pin (8x25)	985	001001210 Cap screw (M8x35)
958	001012109 Nut	972	012017054 Screw extention *	986	012017014 Slide holder
959	001010310 Set screw (M6x25)	973	012017055 Screw extention **	987	012017020 Washer
960	001023008 Key	974	012017018 Bracket	988	012017056 Collar
961	012017022 Gib	975	012017061 Screw (mm) *	989	001021265 Split pin (4x32)
962	012017019 Washer	976	012017062 Screw (inch) *		* Models MS-1400 S/E and MS-175 S/E
963	012017005 Slide	977	012017063 Screw (mm) **		** Models MS-1600 S/E and MS-205 AS/AE

**COOLANT PUMP
(optional)**

MS-MI-420C

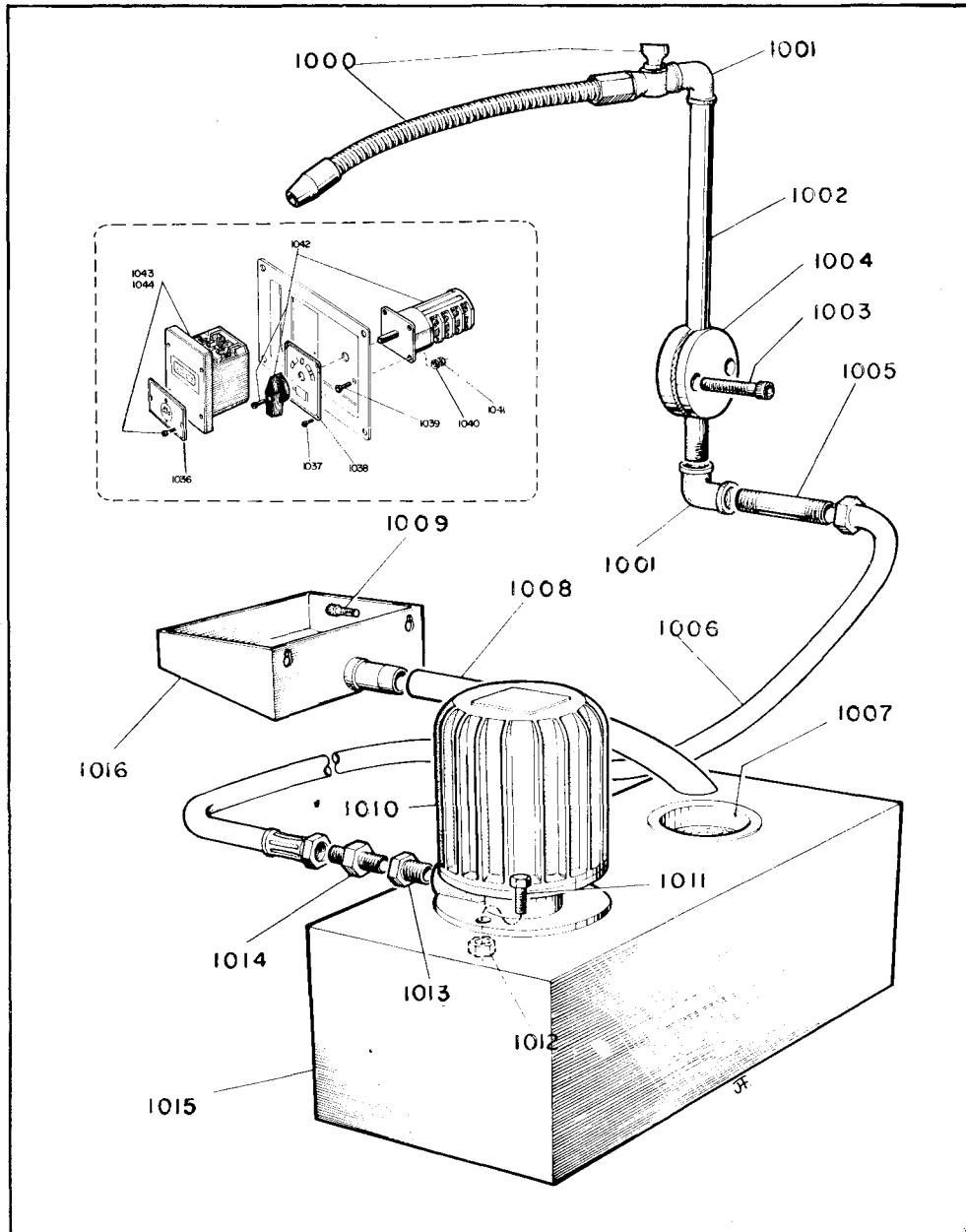

REF. NUMBER	NAME
1000	001131060 Flexible tube
1001	001200002 Elbow
1002	013012007 Pipe
1003	001001214 Cap screw (M8x60)
1004	012012003 Bracket
1005	012012004 Pipe
1006	013012008 Hose
1007	013012003 Filter
1008	013012002 Hose
1009	001003105 Screw (M5x12)
1010	001104003 Pump
1011	001004308 Screw (M6x20)
1012	001012109 Nut
1013	001206005 Sleeve
1014	001203002 Union
1015	013012001 Tank
1016	013012004 Colector
1036	001130014 Data plate
1037	001007305 Cap screw (M3x6)
1038	012015022 Data plate
1039	001013358 Cap screw (M4x16)
1040	001015003 Washer
1041	001012107 Nut
1042	001507016 Cam swith *
1043	001514016 Circuit breaker (220V)*
1044	001514001 Circuit breaker (380/440V)*

* These parts are included in the electrical diagram - page 29

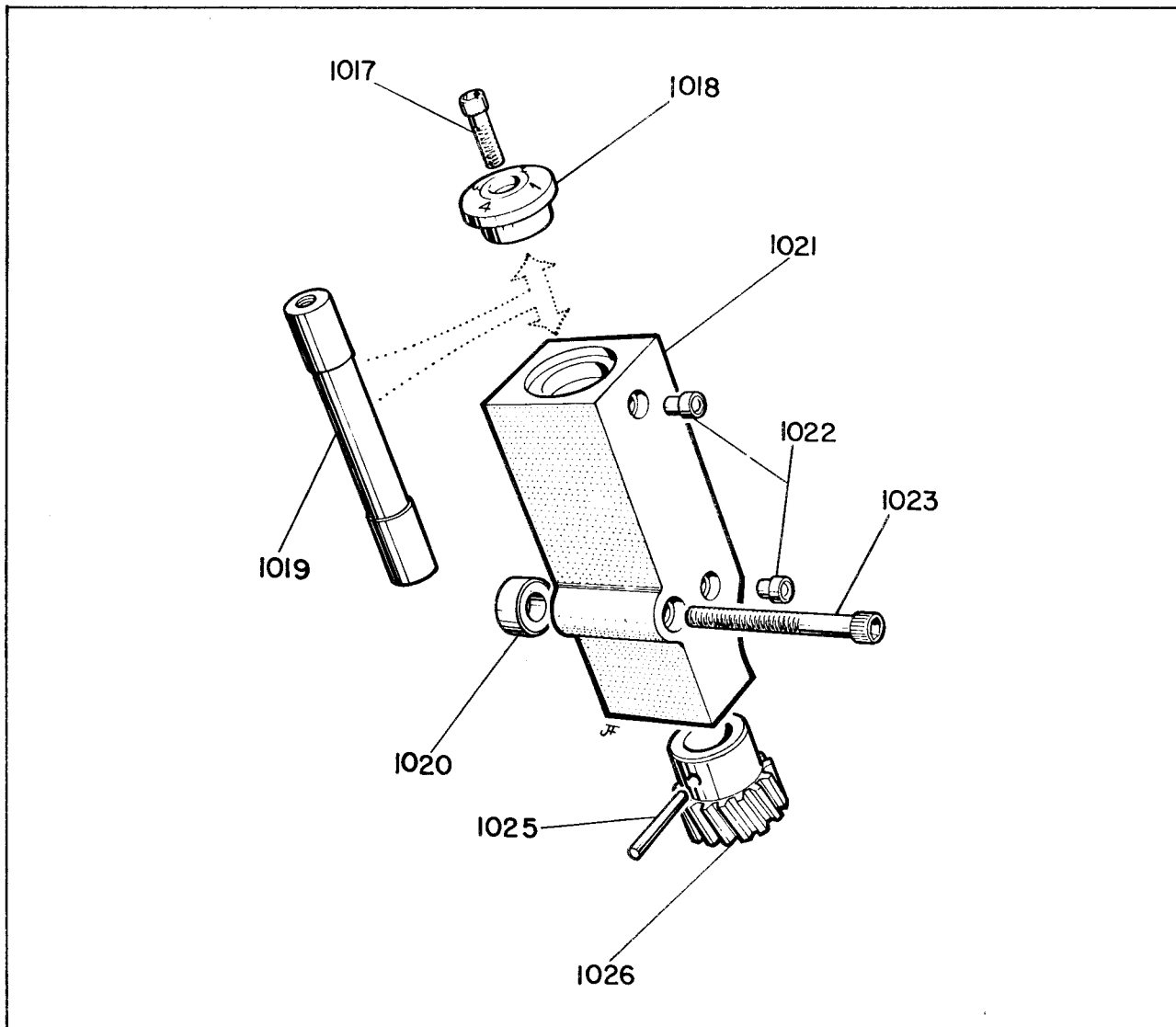

THREADS CUTTING INDICATOR
 (leadscrew pitch - 4 TPI)
 (optional)

MS-MI-421C

REF.	NUMBER	NAME
1017	001001107	Cap Screw (M5x20)
1018	012013004	Dial
1019	012013021	Shaft
1020	012013005	Spacer
1021	012013001	Casting
1022	001122001	Oiler
1023	001001264	Cap Screw (M10x60)
1025	001021263	Split pin (4x28)
1026	013013004	Gear

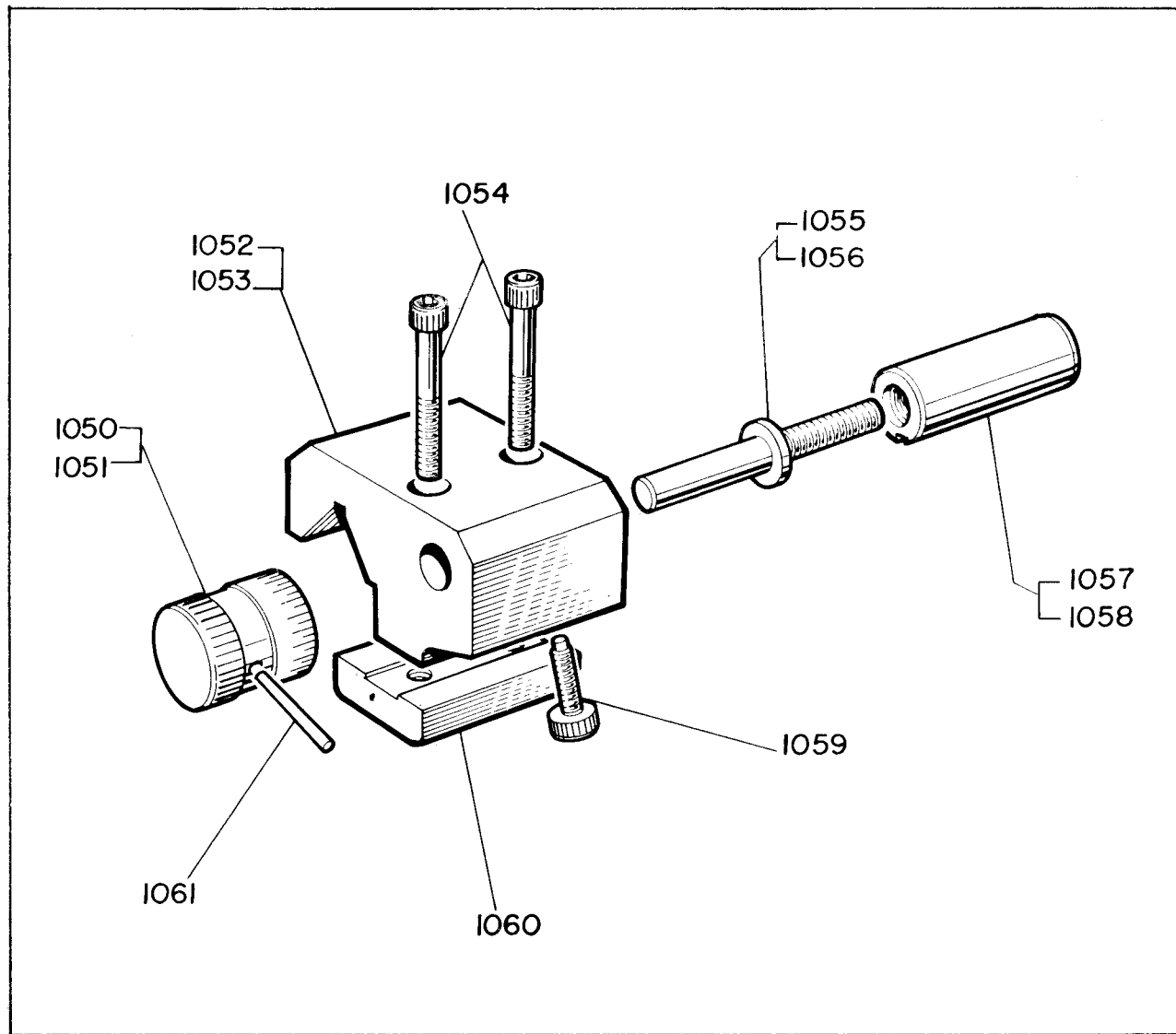

MICROMETER STOP
(optional)

MS-MI-422C

REF.	NUMBER	NAME
1050	012047003	Indexing ring (mm)
1051	012047007	Indexing ring (inch)
1052	012047001	Casting (mm)
1053	012047006	Casting (inch)
1054	001001213	Cap screw (M8x50)
1055	012047005	Screw (mm)
1056	012047009	Screw (inch)
1057	012047004	Stop (mm)
1058	012047008	Stop (inch)
1059	012010008	Knurled head screw
1060	012047002	Slide holder
1061	001017310	Taper pin (3x28)

CHIP GUARD
(optional)

MS-MI-423C

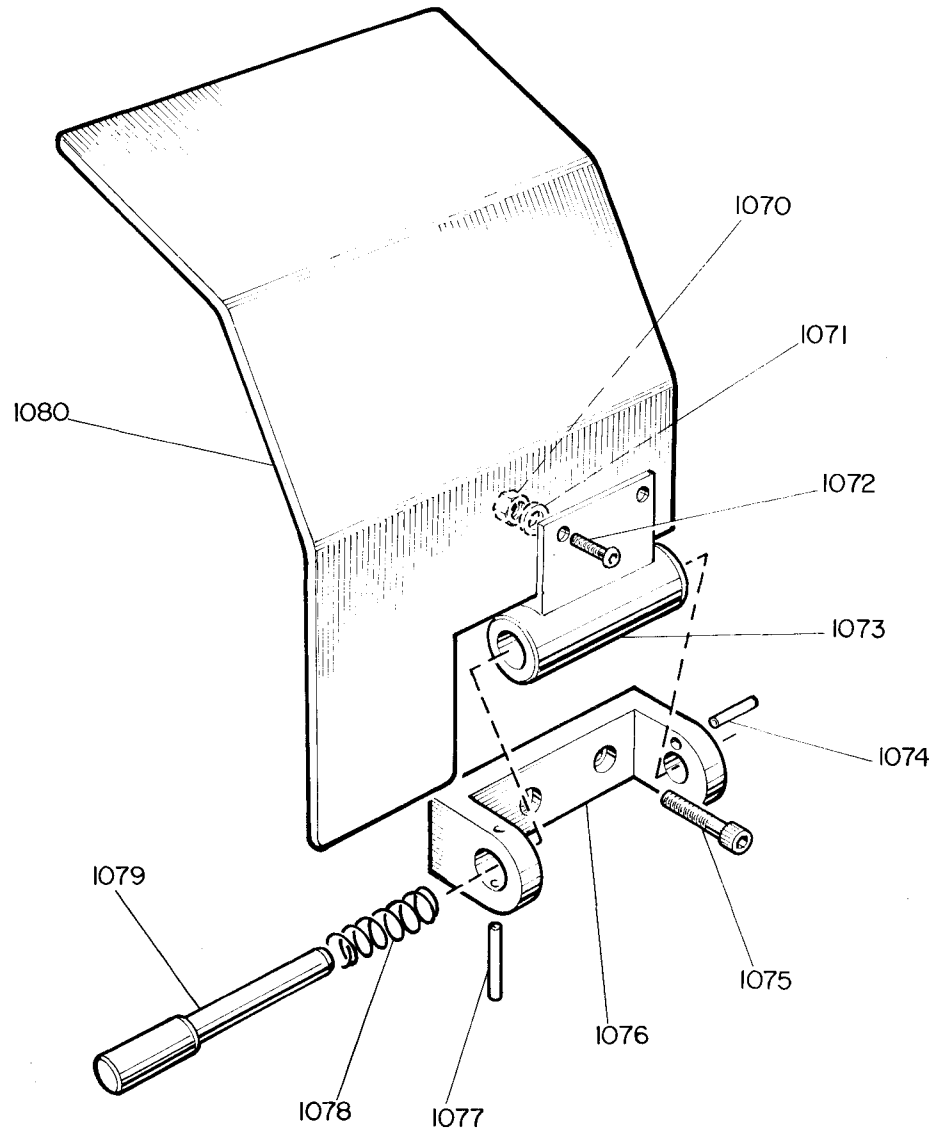

REF.	NUMBER	NAME
1070	001012108	Nut
1071	001014010	Washer
1072	001003105	Cap screw (M5x10)
1073	012046005	Flanged bearing
1074	001021205	Split pin (3x12)
1075	001001156	Cap screw (M6x16)
1076	012046001	Bracket
1077	001021261	Split pin (4x22)
1078	001117240	Spring
1079	012046002	Shaft
1080	012046006	Protector

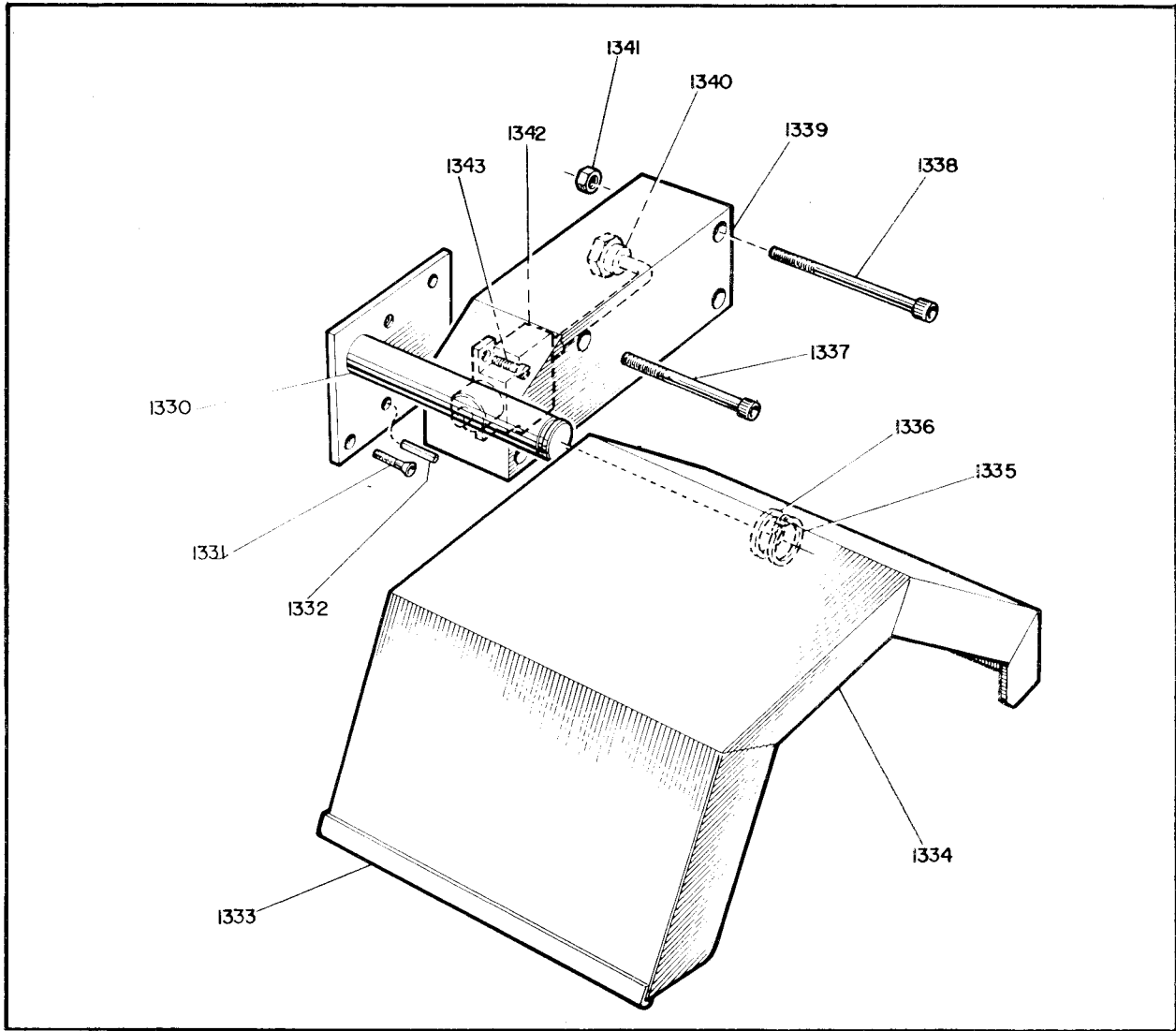

CHUCK GUARD
(optional)

MS-MI-424

REF.	NUMBER	NAME
1330	012039010	Support
1331	001002106	Cap screw (M6x16)
1332	001021365	Split pin (6x32)
1333	001137001	Fitting
1334	012039001	Protector
1335	001033018	Snap ring (20)
1336	012039013	Spacer
1337	001001162	Cap screw (M6x45)
1338	001001164	Cap screw (M6x60)
1339	012039005	Housing
1340	IE-462	Connector
1341	001012109	Nut
1342	IE-633	Micro switch
1343	001007357	Cap screw (M4x10)

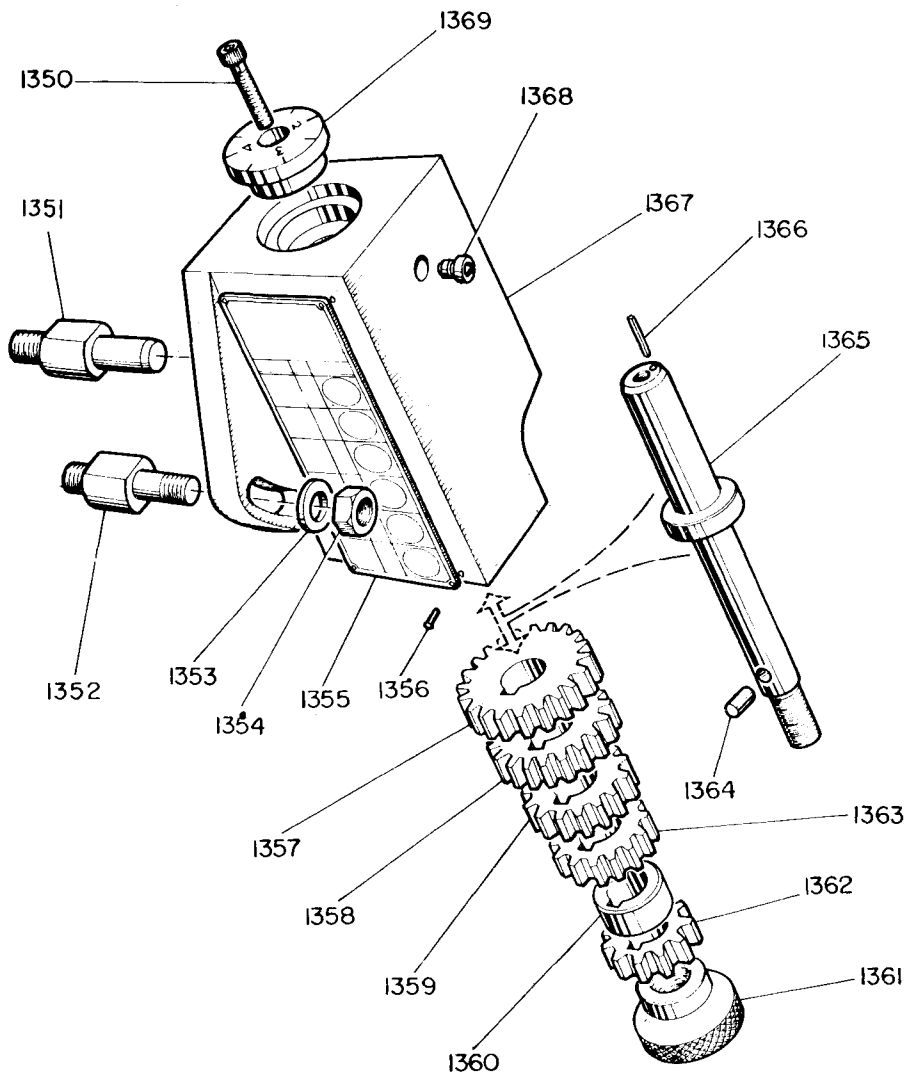

THREADS CUTTING INDICATOR
 (leadscrew pitch - 6mm)
 (optional)

MS-MI-425C

REF.	NUMBER	NAME
1350	001001108	Cap screw (M8x25)
1351	012013018	Pin
1352	012013016	Stud
1353	001014014	Washer
1354	001012111	Nut
1355	012013020	Data plate
1356	001035010	Rivet
1357	012013015	Gear Z= 24
1358	012013014	Gear Z= 22
1359	012013013	Gear Z= 20
1360	012013010	Spacer
1361	012013009	Nut
1362	012013001	Gear Z= 14
1363	012013012	Gear Z= 16
1364	012020402	Pin (5x6)
1365	012013008	Shaft
1366	001021204	Split pin (3x10)
1367	012013007	Casting
1368	001122001	Oiler
1369	012013004	Dial

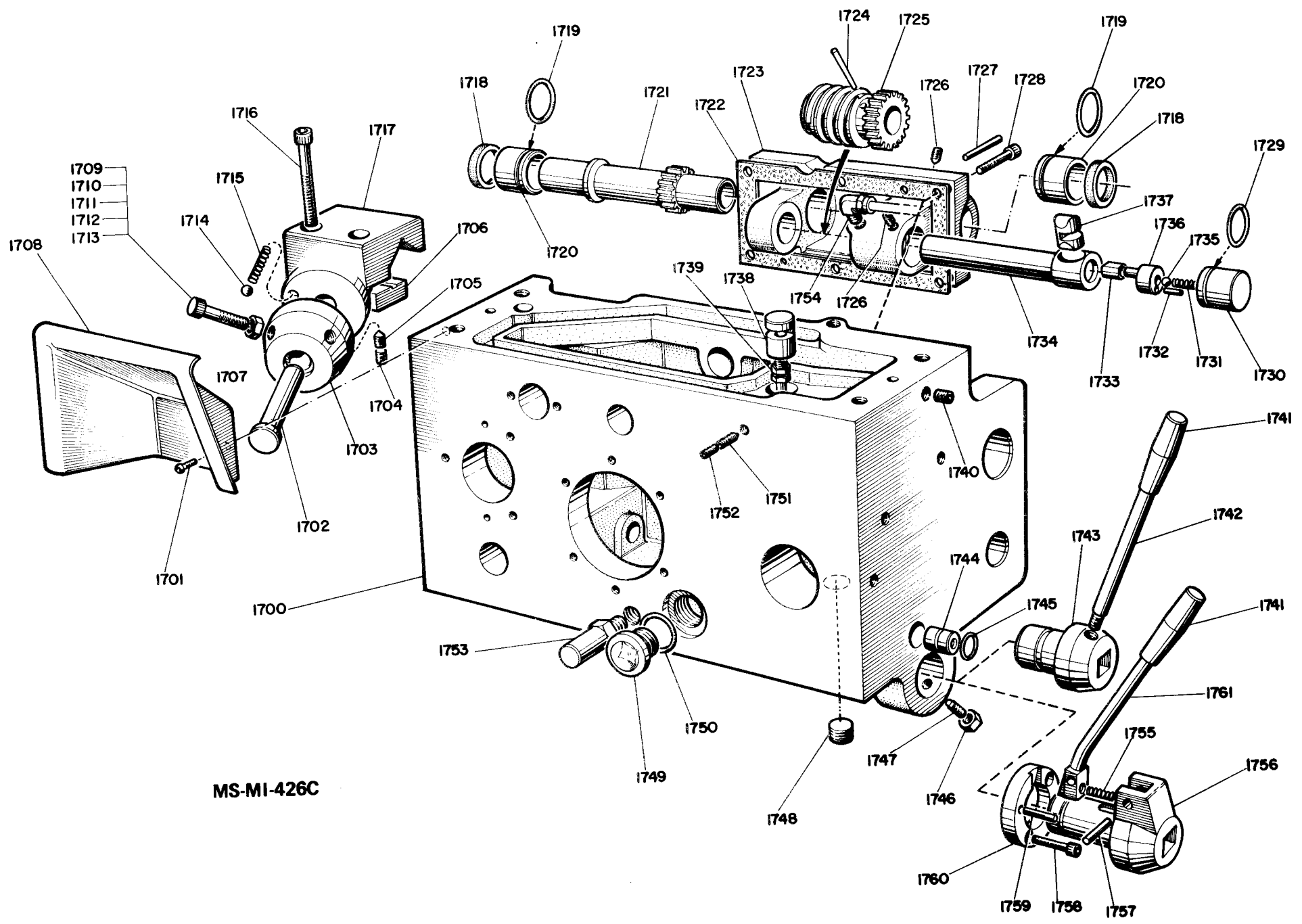

MS-MI-426C

**APRON MS-MI-426C
(right - hand)**

REF. NUMBER	NAME	REF. NUMBER	NAME	REF. NUMBER	NAME
1700	012004301 Casting	1722	Gasket	1744	012004317 Plug
1701	001003105 Cap screw (M5x12)	1723	012004306 Bracket	1745	001133010 Oil ring
1702	012004314 Shaft	1724	001017412 Taper pin (5x32)	1746	001012001 Nut
1703	012004312 Handle boss	1725	012004229 Worm	1747	001010359 Set screw (M8x20)
1704	001008409 Set screw (M10x16)	1726	001009307 Set screw (M6x10)	1748	001205004 Plug
1705	001009409 Set screw (M10x16)	1727	001017406 Taper pin (5x20)	1749	001118010 Oil sight
1706	012004178 Slide holder	1728	001001206 Cap screw (M8x16)	1750	001133117 Oil ring
1707	001012002 Nut	1729	001133119 Oil ring	1751	001009309 Set screw (M6x16)
1708	013004065 Protector (optional)	1730	012004236 Cover	1752	001008307 Set screw (M6x10)
1709	012004182 Screw (M10x33)	1731	001117052 Spring	1753	015004054 Stop
1710	012004183 Screw (M10x43)	1732	001021255 Split pin (4x12)	1754	001229006 Connector
1711	012004184 Screw (M10x48)	1733	012001083 Bushing		
1712	012004185 Screw (M10x53)	1734	012004235 Shaft		
1713	012004186 Screw (M10x58)	1735	001127030 Ball (6,5)		D - THENT CONTROL LEVER
1714	001127040 Ball (8)	1736	012001086 Eccentric pin		(optional)
1715	00117115 Spring	1737	012001084 Impeller	1755	001117090 Spring
1716	001001263 Cap screw (M20x50)	1738	015004066 Bushing	1756	012004056 Handle boss
1717	012004175 Bracket	1739	001227007 Connector	1757	001020462 Pin (6x32)
1718	A-2 -24555 Oil seal	1740	001008407 Set screw (M10x10)	1758	001001107 Cap screw (M5x20)
1719	001133121 Oil ring	1741	001108030 Handle	1759	001021309 Split pin (5x20)
1720	012004032 Bushing	1742	012004045 Lever	1760	012004057 Collar
1721	012004029 Bushing	1743	012004044 Handle boss	1761	012004228 Lever

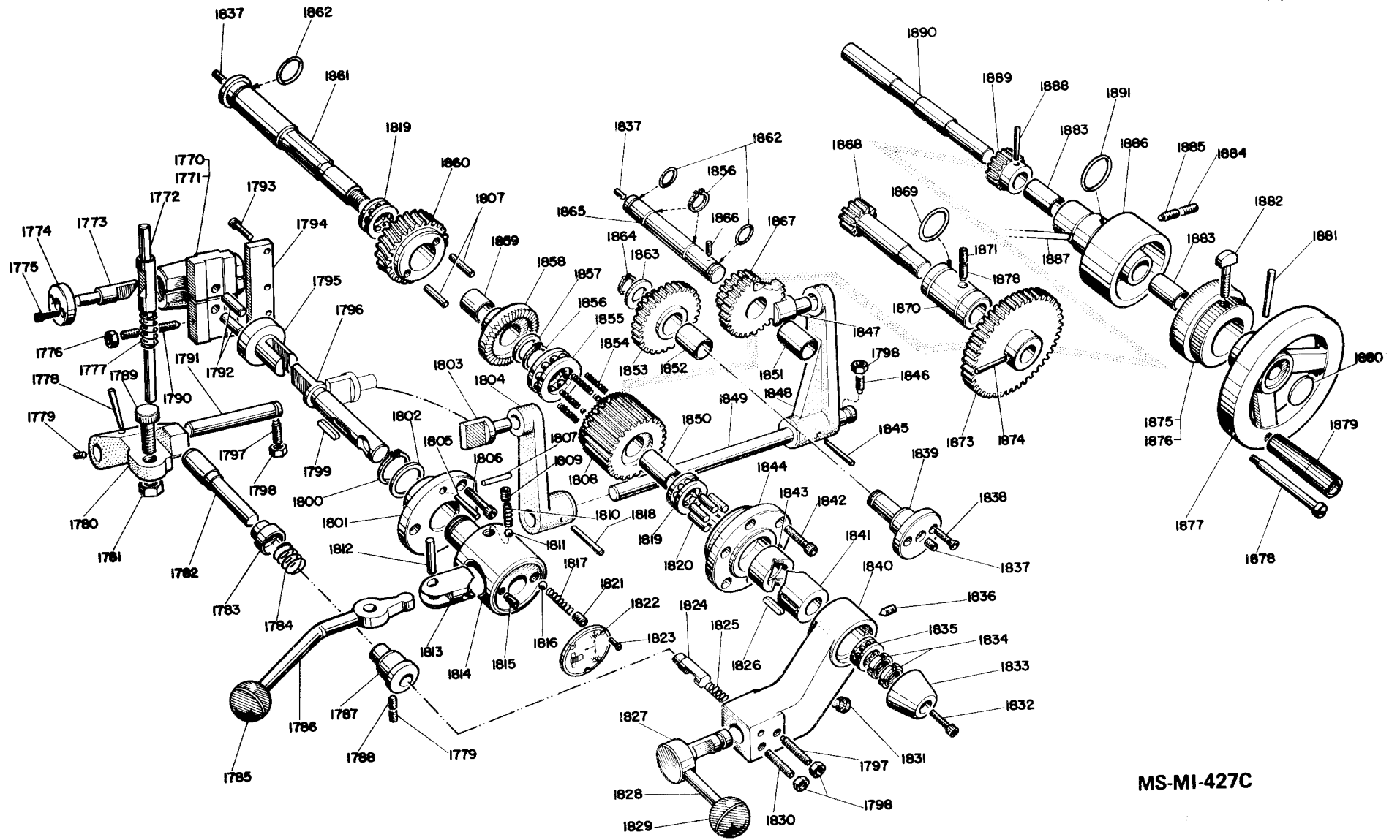

MS-MI-427C

**APRON MS-MI-427C
(right - hand)**

REF.	NUMBER	NAME	REF.	NUMBER	NAME	REF.	NUMBER	NAME
1770	012004212	Half nut (4 TPI)	1811	001127030	Ball (6,5)	1852	001114207	Bushing
1771	012004260	Half nut (6mm)	1812	001020561	Pin (10x28)	1853	012004220	Double gear
1772	012004316	Shaft	1813	012004227	Wedge	1854	001117085	Spring
1773	012004234	Pin	1814	012004215	Handle shifting register	1855	001305019	Bearing 51107
1774	012004233	Cover	1815	001010306	Set screw (M6x10)	1856	001033018	Snap ring (20)
1775	001001155	Cap screw (M6x12)	1816	001127040	Ball (8)	1857	012004251	Spacer
1776	001012110	Nut	1817	001117120	Spring	1858	012004223	Clutch
1777	001117275	Spring	1818	001021312	Split pin (5x26)	1859	001114256	Bushing
1778	001017413	Taper pin (5x36)	1819	001305009	Bearing 51104	1860	012004209	Worm gear
1779	001008308	Set screw (M6x12)	1820	013004121	Pin	1861	012004224	Shaft
1780	012004303	Fork	1821	001008409	Set screw (M10x16)	1862	001133113	Oil ring
1781	001012002	Nut	1822	012004318	Data plate	1863	012004048	Spacer
1782	012004313	Shaft	1823	001036154	CAp screw (M3x8)	1864	001033016	Snap ring (18)
1783	012004258	Spring housing	1824	013004124	Pin	1865	012004245	Shaft
1784	001117410	Spring	1825	001117270	Spring	1866	001009307	Set screw (M6x10)
1785	001105020	Handle	1826	001023105	Key	1867	012004221	Gear
1786	012004237	Lever	1827	012004232	Pin	1868	012004242	Rack pinion
1787	013004123	Bushing	1828	012004249	Lever	1869	001133122	Oil ring
1788	001009308	Set screw (M6x12)	1829	001105030	Handle	1870	012008208	Bushing
1789	015004016	Screw	1830	001008311	Set screw (M6x25)	1871	001008408	Set screw (M10x12)
1790	012004253	Set screw	1831	015004068	Protector	1872	001010409	Set screw (M10x16)
1791	012004307	Shaft	1832	001001106	Cap screw (M5x16)	1873	012004219	Gear
1792	001020558	Pin (10x18)	1833	012004207	Cover	1874	001017414	Taper pin (5x40)
1793	001001105	Cap screw (M5x12)	1834	001030003	Nut	1875	012004216	Indexing ring (mm)
1794	012004252	Strip	1835	001305007	Bearing 51103	1876	012004217	Indexing ring (inch)
1795	012004311	Cam	1836	001009307	Set screw (M6x10)	1877	001100040B	Handwheel
1796	012004226	Shaft	1837	001008556	Set screw (M5x8)	1878	001109010A	Shaft
1797	001010309	Set screw (M6x20)	1838	001002105	Cap screw (M6x12)	1879	001109005A	Handle
1798	001012109	Nut	1839	012004315	Shaft	1880	001130105	Cover
1799	001023106	Key	1840	012004302	Bracket	1881	001017416	Taper pin (5x50)
1800	001033027	Snap ring (32)	1841	012004240	Cam	1882	013006023A	Screw
1801	012004310	Cover	1842	001001156	Cap screw (M6x16)	1883	001114208	Bushing
1802	012004254	Spacer	1843	012004241	Cam	1884	001008408	Set screw (M10x12)
1803	012004246	Shifting fork	1844	012004204	Cover	1885	001010408	Set screw (M10x16)
1804	012004304	Fork	1845	001021312	Split pin (5x26)	1886	012004203	Bushing
1805	001017406	Taper pin (5x20)	1846	001010308	Set screw (M6x16)	1887	001263102	Pipe
1806	001001155	Cap screw (M6x12)	1847	012004309	Shifting fork	1888	001017412	Taper pin (5x32)
1807	001020460	Pin (6x24)	1848	012004305	Fork	1889	012004243	Gear
1808	012004222	Gear	1849	012004308	Shaft	1890	012004244	Shaft
1809	001008357	Set screw (M8x10)	1850	001114259	Bushing	1891	001133128	Oil ring
1810	001117045	Spring	1851	001114258	Bushing			



NARDINI

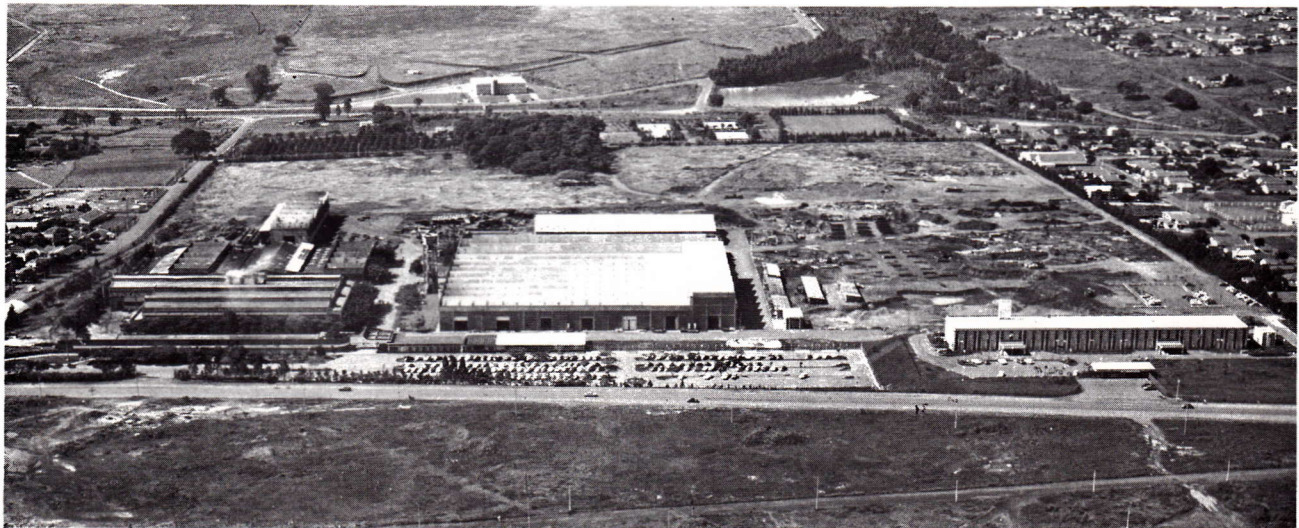

INDÚSTRIAS **NARDINI** S.A.

Avenida Monsenhor Bruno Nardini, 1735 — CEP 13470 — SP — Brazil
Phone: (0194) 61.4026 — Telex: (019) 1551 HTIB BR